

FOREWORD

The electric membership cooperatives (EMCs) of Georgia assembled this booklet as a training guide to promote standard wiring requirements. This booklet is comprised of sections of the National Electrical Code. It is intended as a training guide for students to be used in a supervised classroom environment that does not have access to the official National Electric Code standards.

This booklet is a NOT-FOR-SALE item, intended to be provided to all users free of charge. This booklet should only be used as a wiring guideline and does not supersede any National Electrical Codes, EMC special wiring requirements, or any other authority having jurisdiction. Any consumer or licensed electrician planning to do electrical work should contact their local authorities for approval of their work.

This booklet is intended to be used as a resource in preparation for the EMC/FFA Wiring Contest (Career Development Event). The annual contest is sponsored by the electric cooperatives in cooperation with the FFA. The purpose of the contest is to promote and expand educational programs in electrification for students of agricultural education. The electric membership corporations throughout Georgia sponsor these activities as a means of promoting education in the safe, efficient use of electrical energy.

Participants in the contest are students in grades 9-12 enrolled in agricultural education and active members of the Georgia FFA. Students compete first in area contests; the top two contestants from each area move on to the state competition held each year at the FFA/FCCLA Center in Covington. Scholarships awarded to area and state winners can be used at college or vocational schools.

For more information on this program, contact the Member Services department at your local electric cooperative, speak with an FFA advisor, contact Georgia EMC at 1-800-544-4362 or go to www.georgiaemc.com.

revised March 2006

1	GENERAL	Page
1-1	through 1-10 General Wiring Statements	1
2	DEFINITIONS	
2-1	through 2-38 Electrical Terms, Devices, Materials & Equipment Defined	2
3	SERVICE ENTRANCES	
3-1	Point of Attachment	6
3-2	Clearance for Overhead Service	7
3-3	Service Drop Attachment	7
3-4	Underground Service	8
3-5	Residential Service Requirements	8
3-6	Conduit	8
3-7	Conductors	9
3-8	Meter Base	10
4	GROUNDING	
4-1	Service Grounding Wire	11
4-2	Safety Bonding	12
4-3	Equipment Grounding	12
4-4	Grounding Electrode (ROD)	13
5	PROTECTIVE EQUIPMENT	
5-1	Service Equipment Approval	14
5-2	Service Equipment Location	14
5-3	Mounting of Equipment	15
5-4	Marking Equipment & Circuits	15
5-5	Overcurrent Protection	16
6	BRANCH CIRCUIT WIRING	
6-1	Length of Free Conductor	16
6-2	Conductor Continuity	17
6-3	Splices	17
6-4	Circuit Identification	17
6-5	Cable Clamps and Connectors	17
6-6	Non-Metallic-Sheathed Cable	18
6-7	Knockout Closers	18
6-8	General Purpose Outlets	18
6-9	Small Appliance Circuits	19
6-10	Dwelling Unit Receptacle Outlets	20
6-11	Ground Fault Protection	24
6-12	Arc-Fault Protection	26
6-13	Boxes	27
6-14	Number of Conductors	27
6-15	Conduit	31
7	LIGHT CIRCUIT WIRING	
7-1	Lighting Outlets Required	31
7-2	Fixtures in Clothes Closets	32

7-3	Cove Lighting	33
7-4	Flush and Recessed Lighting Fixtures	33
7-5	Adjacent Combustible Materials	33
8	CONDUCTOR SIZING BASED ON VOLTAGE DROP	
8-1	Branch Circuit Conductor Sizing	33
9	COOKING APPLIANCES	
9-1	Installation	34
10	WATER HEATER WIRING	
10-1	Installation	34
11	CLOTHES DRYER WIRING	
11-1	Receptacle	34
11-2	Grounding	34
11-3	Bonding	35
12	FIXED MOTOR-DRIVEN APPLIANCES	
12-1	Installation and Location	35
12-2	Rating	35
12-3	Devices Other Than Fuses	35
13	ELECTRIC SPACE HEAT WIRING	
13-1	General	35
13-2	Conductor Sizes	35
13-3	Portable Heater Receptacles	36
13-4	Derating of Conductors	36
13-5	Thermostats	37
14	CENTRAL SPACE HEATING AND AIR CONDITIONING EQUIPMENT	
14-1	General	37
14-2	Location and Clearance	37
14-3	Disconnecting Means	37
14-4	Overcurrent Protection	38
14-5	Circuit Capacity	38
14-6	Low Voltage Control Wiring	38
15	AGRICULTURAL BUILDING	
15-1	Scope	39
15-2	Definitions	39
15-3	Other Articles	39
15-4	Surface Temperatures	40
15-5	Wiring Methods	40
15-6	Switches, Receptacles, etc.	41
15-7	Motors	41
15-8	Lighting Requirements	41
15-9	Electrical Supply from a Distribution Point	42

16	MOBILE HOMES (NEC 550)	page
16-1	Definitions	44
16-2	Mobile Home Services	44
16-3	Grounding	45

17	OUTSIDE WIRING	
17-1	Installation	46

18	UNDERGROUND WIRING	
18-1	Underground Feeder	47

TABLES

NEC Table 310.15(B)(6) – Sizing Service Entrance Cable	10
NEC Table 250.66 – Grounding Electrode Conductor	12
NEC Table 314.16(A) - Metal Boxes	29
NEC Table 314.16(B) - Volume Required per Conductor	29
NEC Table 310.16 - Allowable Ampacities of Conductors	49
NEC Table C.1 - Conductors in Conduit	57
NFEC Table 8 - Single Phase Motor Currents	58
NFEC Table 16 - Conductor Sizing	59

iv

DIAGRAMS

NEC Exhibit 100.6 - Feeder and Branch Circuits	3
Clearance for Overhead Service	7
Rooftop Clearances for Overhead Service	8
Underground Meter Installation	10
Method for determining # of Receptacles per Branch Circuit	18
NEC Exhibit 210.24 – Wall Spacing of Receptacles	20
NEC Exhibit 210.25 – Small-Appliance Branch Circuits	21
NEC Exhibit 210.26 – Receptacle Spacing in Countertops	23
NEC Exhibit 210.9 – GFCI-Protection in Bathrooms	26
EMC Diagram 1 - Flush-type Boxes	30
EMC Diagram 2 - Double Throw Switch Installation	50

EXAMPLES

Derating Conductor Load	36
Residential Wiring Calculations	51

GEORGIA’S ELECTRIC COOPERATIVES	60
--	----

1. GENERAL

- 1.1 The latest issue of the National Electrical Code (2005 edition) as published by the National Fire Protection Association (NFPA), along with OSHA Rules and Regulations on Electrical Construction, is used as a wiring guide to assure a safe and adequate electrical installation.
- 1.2 Workmanship: Electrical equipment shall be installed in a neat and workmanlike manner. *OSHA*
- 1.3 Conductors normally used to carry current shall be of copper unless otherwise provided in this Code. Where the conductor material is not specified, the sizes given in this Code shall apply to copper conductors. Where other materials are used, the size shall be changed accordingly. *NEC 110.5*
- 1.4 Switches or circuit breakers shall not disconnect the grounded conductor of a circuit. *NEC 404.2(B)*
- 1.5 General use switches and circuit breakers shall clearly indicate whether they are in the open (off) or closed (on) position. Where these switch or circuit breaker handles are operated vertically, the up position of the handle shall be the "on" position. Exception: Vertically operated double-throw switches shall be permitted to be in the closed (on) position with the handle in either the up or down position. *NEC 404.7*
- 1.6 Conductors with white or gray insulation or insulation with three continuous white stripes on other than green insulation shall be used as the grounded conductor in the circuit. *NEC 200.7(A)* When using three conductor SE cable, the bare conductor shall be used as the grounded conductor. *NEC 230.41*
- 1.7 If a conductor with insulation that is white or gray or that has three continuous white stripes is used for other than a grounded conductor, the insulation must be reidentified at its termination and at each location where the conductor is visible and accessible. *NEC 200.7*
- 1.8 On outlets requiring a grounded conductor, the grounded conductor shall be attached to the terminal that is substantially white (silver) in color. *NEC 200.10 (B)*
- 1.9 Reference sources identified by initials in parentheses at the end of a paragraph and in table and diagram headings are as follows:

NEC National Electrical Code
OSHA Occupational Safety and Health Act
REA Rural Electrification Administration
NFEC National Food and Energy Council

1

- 1.10 The licensed electrician, contractor, or consumer planning a wiring installation should contact the local authority for any interpretations or modifications of these Wiring Rules.

2. DEFINITIONS (NEC Article 100)

- 2.1 **ACCESSIBLE:** (As applied to equipment) Admitting close approach: not guarded by locked doors, elevation or other effective means.
- 2.2 **ACCESSIBLE:** (As applied to wiring methods) Capable of being removed or exposed without damaging the building.
- 2.3 **ACCESSIBLE, READILY:** (Readily accessible) Capable of being reached quickly for operation, renewal, or inspections, without requiring those to whom ready access is requisite to climb over or remove obstacles or to resort to portable ladders, chairs, etc.
- 2.4 **AMPACITY:** The current in amperes a conductor can carry continuously under the conditions of use without exceeding its temperature rating.
- 2.5 **APPLIANCE:** An appliance is utilization equipment, generally other than industrial, normally built in standardized sizes or types, which is installed or connected as a unit to perform one or more functions such as clothes washing, air conditioning, food mixing, deep frying, etc.
- 2.6 **APPROVED:** Acceptable to the authority having jurisdiction. The phrase "authority having jurisdiction" is used in NFPA documents in a broad manner since jurisdictions and "approval" agencies vary, as do their responsibilities. Where public safety is primary, the "authority having jurisdiction" may be a federal, state, local, or other regional department or individual such as a fire chief, fire marshal, chief of a fire prevention bureau, labor department, health department, building official, electrical inspector, or others having statutory authority. For insurance purposes, an insurance inspection department, rating bureau, or other insurance company representative may be the "authority having jurisdiction." In many circumstances the property owner or the owner's designated agent assumes the role of the "authority having jurisdiction;" at government installations, the commanding officer or departmental official may be the "authority having jurisdiction."
- 2.7 **AUTOMATIC:** Self-acting, operating by its own mechanism when actuated by some impersonal influence, as for example, a change in current, pressure, temperature, or mechanical configuration.
- 2.8 **BRANCH CIRCUIT:** The circuit conductors between the final over current device protecting the circuit and the outlet(s).

- 2.9 **BRANCH CIRCUIT, APPLIANCE:** A branch circuit supplying energy to one or more outlets to which appliances are to be connected; such circuits to have no permanently connected lighting fixtures not a part of an appliance. Appliance branch circuits for a kitchen, pantry, etc. and for laundry areas are not permitted to have any other outlets or permanently connected lighting fixtures connected to them.
- 2.10 **BRANCH CIRCUIT, GENERAL PURPOSE:** A branch circuit that supplies two or more receptacles or outlets for lighting and appliances.
- 2.11 **BRANCH CIRCUIT, INDIVIDUAL:** A branch circuit that supplies only one utilization equipment. An individual branch circuit shall be permitted to supply any load for which it is rated: for example, one range, or one space heater, or one motor. NEC 210-23 A branch circuit may be installed to supply one duplex receptacle, which can accommodate two cord-connected and plug-connected appliances or similar equipment. This circuit would not be considered an individual branch circuit.
- 2.12 **BRANCH CIRCUIT, MULTIWIRE:** A branch circuit that consists of two or more ungrounded conductors that have a voltage between them and a grounded conductor that has equal voltage between it and each ungrounded conductor of the circuit and that is connected to the neutral or grounded conductor of the system.

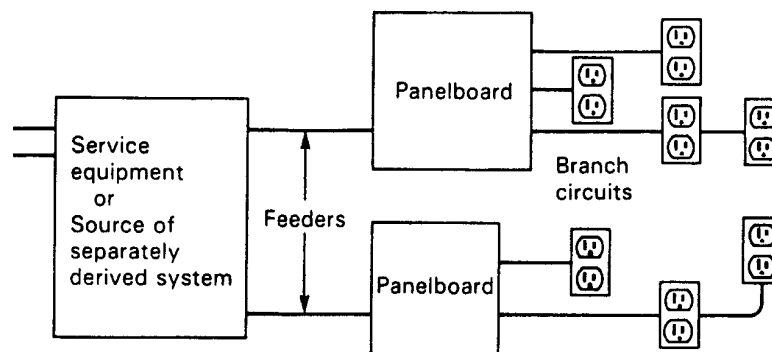

Exhibit 100.6 Feeder and Branch Circuits

- 2.13 **CIRCUIT BREAKER:** A device designed to open and close a circuit by nonautomatic means and to open the circuit automatically on a predetermined over current without damage to itself when properly applied within its rating.
- 2.14 **CONCEALED:** Rendered inaccessible by the structure or finish of the building. Wires in concealed raceways are considered

concealed, even though they may become accessible by withdrawing them.

- 2.15 CONTINUOUS LOAD: A load where the maximum current is expected to continue for three hours or more.
- 2.16 CONTROLLER: A device or group of devices that serves to govern, in some predetermined manner, the electrical power delivered to the apparatus to which it is connected.
- 2.17 DEVICE: A unit of an electric system that is intended to carry or control, but not utilize, electrical energy. Units, such as switches, circuit breakers, fuse holders, receptacles, attachment plugs, and lamp holders that distribute or control but do not consume electricity are termed "devices."
- 2.18 DISCONNECTING MEANS: A device, group of devices, or other means by which the conductors of a circuit can be disconnected from their source of supply.
- 4 2.19 DWELLING:
 - 2.19.1 Dwelling Unit: A single unit, providing complete and independent living facilities for one or more persons, including permanent provisions for living, sleeping, cooking and sanitation.
 - 2.19.2 One Family Dwelling: A building consisting solely of one dwelling unit.
 - 2.19.3 Two Family Dwelling: A building consisting solely of two dwelling units.
 - 2.19.4 Multifamily Dwelling: A building containing three or more dwelling units.
- 2.20 ENCLOSED: Surrounded by a case, housing, fence, or walls that prevents persons from accidentally contacting energized parts.
- 2.21 EQUIPMENT: A general term including material, fittings, devices, appliances, luminaries (fixtures), apparatus, and the like used as a part of, or in connection with, an electrical installation.
- 2.22 EXPOSED: (As applied to wiring methods) On or attached to the surface or behind panels designed to allow access.
- 2.23 FEEDER: All circuit conductors between the service equipment or the source of separately derived system or other power supply source and the final branch-circuit overcurrent device.
- 2.24 GROUNDED CONDUCTOR: A system or circuit conductor that is intentionally grounded.

- 2.25 GROUNDING CONDUCTOR: A conductor used to connect equipment or the grounded circuit of a wiring system to a grounding electrode or electrodes.
- 2.26 GROUNDING CONDUCTOR, EQUIPMENT: The conductor used to connect the non-current-carrying metal parts of equipment, raceways, and other enclosures to the system grounded conductor, the grounding electrode conductor, or both at the service equipment or at the source of a separately derived system.
- 2.27 IDENTIFIED: (As applied to equipment) Recognizable as suitable for the specific purpose, function, use, environment, application, etc., where described in a particular Code requirement.
- 2.28 LOCATION:
 - 2.28.1 Damp Location: Partially protected locations under canopies, marquees, roofed open porches, and like locations, and interior locations subject to moderate degrees of moisture, such as some basements, some barns and some cold-storage warehouses.
 - 2.28.2 Dry Location: A location not normally subject to dampness or wetness. A location classified as dry may be temporarily subject to dampness or wetness, as in the case of a building under construction.
 - 2.28.3 Wet Location: Installations underground or in concrete slabs or masonry in direct contact with the earth, and locations subject to saturation with water or other liquids, such as vehicle washing areas, and locations exposed to weather and unprotected.
- 2.29 OUTLET: A point on the wiring system at which current is taken to supply utilization equipment.
- 2.30 RACEWAY: An enclosed channel designed expressly for holding wires, cables, or bus bars, with additional functions as permitted in this Code.

Raceways may be of metal or nonmetallic materials. Raceways include, but are not limited to, rigid metal conduit, rigid nonmetallic conduit, intermediate metal conduit, liquid tight flexible conduit, flexible metallic tubing, flexible metal conduit, electrical nonmetallic tubing, electrical metallic tubing, under floor raceways, cellular concrete floor raceways, cellular metal floor raceways, surface raceways, wireways, and busways.
- 2.31 RAIN-TIGHT: Constructed or protected so that exposure to a beating rain will not result in the entrance of water under specified test conditions.
- 2.32 RECEPTACLE: A receptacle is a contact device installed at the outlet for the connection of an attachment plug.

- 2.33 **SERVICE DROP:** The overhead service conductors from the last pole or other aerial support to and including the splices, if any, connecting to the service-entrance conductors at the building or other structure.
- 2.34 **SERVICE-ENTRANCE CONDUCTORS, OVERHEAD SYSTEM:** The service conductors between the terminals of the service equipment and a point usually outside the building, clear of building walls, where joined by tap or splice to the service drop.
- 2.35 **SERVICE-ENTRANCE CONDUCTORS, UNDERGROUND SYSTEM:** The service conductors between the terminals of the service equipment and the point of connection to the service lateral. Where service equipment is located outside the building walls, there may be no service entrance conductors, or they may be entirely outside the building.
- 2.36 **SERVICE EQUIPMENT:** The necessary equipment, usually consisting of a circuit breaker or switch and fuses, and their accessories, connected to the load end of service conductors to a building or other structure, or an otherwise designated area, and intended to constitute the main control and cutoff of the supply.
- 2.37 **SPECIAL PERMISSION:** The written consent of the authority having jurisdiction.
- 2.38 **SWITCHES:**
- 2.38.1 **General-Use Switch:** A switch intended for use in general distribution and branch circuits. It is rated in amperes, and it is capable of interrupting its rated current at its rated voltage.
- 2.38.2 **Motor-Circuit Switch:** A switch, rated in horsepower, capable of interrupting the maximum operating overload current of a motor of the same horsepower rating as the switch at the rated voltage.
- 2.38.3 **Weatherproof:** Constructed or protected so that exposure to the weather will not interfere with successful operation. Rainproof, rain tight, or watertight equipment can fulfill the requirements for weatherproof where varying weather conditions other than wetness, such as snow, ice, dust, or temperature extremes, are not a factor.

3. SERVICE ENTRANCES

- 3.1 **POINT OF ATTACHMENT:** The point attachment of the service drop conductors to a building or other structure shall provide the minimum clearances as specified in NEC 230.9 and 230.24. In no case shall this point of attachment be less than 3.0 m (10 ft) above finished grade NEC 230.26. The means of attachment NEC 230.27 will usually be provided by the electric utility, and will be in accordance with the local authority of jurisdiction.

- 3.2 **CLEARANCE FOR OVERHEAD SERVICE:** The vertical clearance of the conductor above the roof level shall be maintained for a distance of not less than 3 feet (900 mm) in all directions from the edge of the roof. *NEC 230.24(A)*

Service-drop conductors, where not in excess of 600 volts, nominal, shall have the following minimum clearance from final grade: *NEC 230.24(B)*

- 3.2.1 Ten feet (3.0 m) at the electric service entrance to buildings, also at the lowest point of the drip loop of the building electric entrance, and above areas or sidewalks accessible only to pedestrians, measured from final grade or other accessible surface only for service-drop cables supported on and cabled together with a grounded bare messenger where the voltage does not exceed to 150 volts to ground.
- 3.2.2 Twelve feet (3.7 m) over residential property and driveways, and those commercial areas not subject to truck traffic where the voltage does not exceed 300 volts to ground.
- 3.2.3 Fifteen feet (4.5 m) for those areas listed in the 12 ft. (3.7 m) classification where the voltage exceeds 300 volts to ground.
- 3.2.4 Eighteen feet (5.5 m) over public streets, alleys, roads, parking areas subject to truck traffic, driveways on other than residential property, and other land such as cultivated, grazing, forest, and orchard.

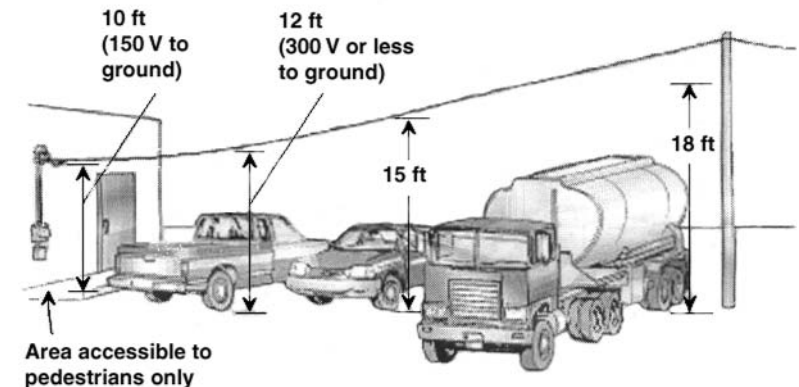

- 3.2.5 A coupling will not be permitted between the weatherhead and the point where a service raceway extends through the roof.
- 3.3 **SERVICE DROP ATTACHMENT:** The point of attachment of the service-drop conductors to a building or other structure shall

provide the minimum clearances as specified in 3-2 of this booklet and NEC 230.24. In no case shall this point of attachment be less than 10 ft (3.0m) above finished grade. *NEC 230.26*

3.4 UNDERGROUND SERVICE: Contact your local electric authority office for the latest Underground Service Policy Rules and Regulations.

3.5 RESIDENTIAL SERVICE REQUIREMENTS:

NUMBER OF SERVICES: A building or other structure served shall be supplied by only one service unless permitted in *NEC 230.2(A)* through *(D)*.

NOTE: The National Electric Code permits a separate service for each occupancy in multiple-occupancy buildings, provided the service-entrance conductors are installed outside of the building, or other structure in accordance with NEC 230.6. Many electric power companies have specifications and have adopted special regulations covering certain types of electrical loads and service equipment that may be energized from their lines. It is advisable to consult with the serving authority to determine line capacities before designing electrical services for large buildings.

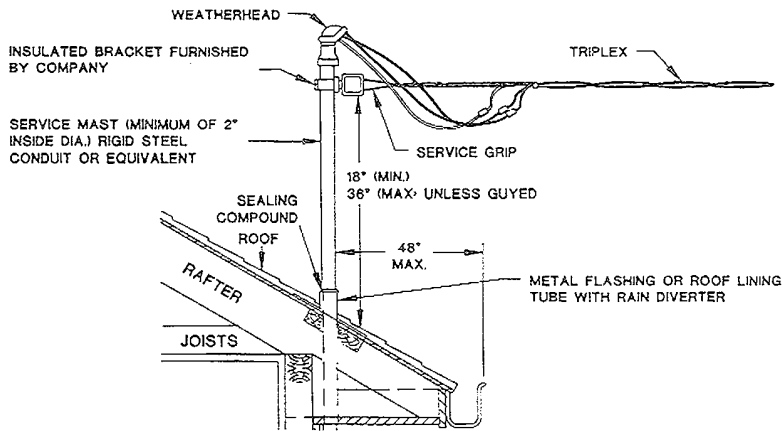

3.6 CONDUIT:

3.6.1 When a service mast is used for the support of service-drop conductors, it shall be of adequate strength or be supported by braces or guys to withstand safely the strain imposed by the service drop. Where raceway-type service masts are used, all raceway fittings shall be identified for use with service masts. Only power service-drop conductors shall be permitted to be attached to a service mast. *NEC 230.28*

3.6.2 For all services extending through the roof, a minimum of 2 inches (50.8 mm) rigid galvanized steel conduit or intermediate metal conduit is required for mechanical strength in order to support service drop.

3.6.3 The use of electrical metallic tubing (EMT) shall be permitted for both exposed and concealed work. Electrical metallic tubing shall not be used: (1) Where, during installation or afterward, it will be subject to severe physical damage; (2) Where protected from corrosion solely by enamel; (3) In cinder concrete or cinder fill where subject to permanent moisture unless protected on all sides by a layer of noncinder concrete at least 2 inches (50 mm) thick or unless the tubing is at least 18 inches (450 mm) under the fill. Where practicable, dissimilar metals in contact anywhere in the system shall be avoided to eliminate the possibility of galvanic action. *NEC 358.10 and 358.12*

3.6.4 Ferrous or non-ferrous electric metallic tubing, elbows, couplings, and fittings shall be permitted to be installed in concrete, in direct contact with the earth, or in areas subject to severe corrosive influences where protected by corrosion protection or judged suitable for the condition. *NEC 358.10*

3.6.5 Where a conduit enters a box, fitting, or other enclosure, a bushing shall be provided to protect the wire from abrasion unless the design of the box, fitting, or enclosure is such as to afford equivalent protection. *NEC 342.46*

3.7 CONDUCTORS:

3.7.1 Clearance From Building Openings:

Service conductors installed as open conductors or multi-conductor cable without an overall outer jacket shall have a clearance of not less than 3 feet (900 mm) from windows that are design to be opened, doors, porches, balconies, ladders, stairs, fire escapes or similar locations. *NEC 230.9(A)*

Service conductors run above the top level of a window shall be permitted to be less than the 3 feet (900 mm) requirement above. *NEC 230.9 (Exception A)*

Overhead service conductors shall not be installed beneath openings through which materials may be moved, such as openings in farm and commercial buildings, and shall not be installed where they obstruct entrance to these building openings. *NEC 230.9(C)*

3.7.2 Service entrance cable type SE may be installed for any residential installation up to and including 200 ampacity, unless prohibited by local (city or county) authority.

3.7.3 Refer to table 310.16, section 18 for nonresidential (see page 49).

**Conductor Types and Sizes for 120/240 volts,
3 wire single phase dwelling**
NEC Table 310.15(B)(6)

Copper	Aluminum and Copper-Clad AL	Rating in Service Amps
AWG	AWG	
4	2	100
3	1	110
2	1/0	125
1	2/0	150
1/0	3/0	175
2/0	4/0	200
3/0	250 kcmil	225
4/0	300 kcmil	250
250 kcmil	350 kcmil	300
350 kcmil	500 kcmil	350
400 kcmil	600 kcmil	400

10

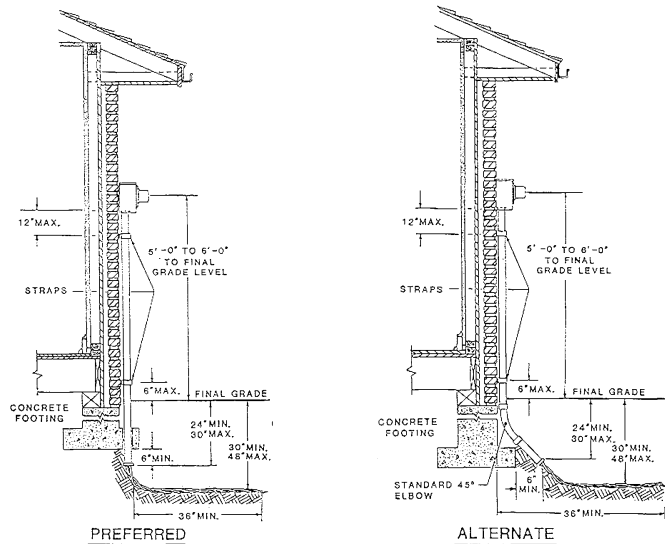

3.8 METER BASE:

- 3.8.1 Meters, meter sockets, or meter disconnect switches nominally rated not in excess of 600 volts shall be permitted to be connected to the supply side of the service disconnecting means. *NEC 230.82(2),(3)*
- 3.8.2 Meter base installed on a masonry wall shall be of the type approved for this purpose.
- 3.8.3 Meter base installed for an underground service shall be of the type approved for this purpose.

- 3.8.4 Meter base for potential (PT) or current transformer (CT) metering will be supplied by the utility, but the use of equipment must be approved before the installation.
- 3.8.5 **Contact your local utility prior to electrical construction as these electrical requirements may vary according to the local authority.**

4. GROUNDING

- 4.1 SERVICE GROUNDING WIRE:
 - 4.1.1 Size of Alternating Current Grounding Electrode Conductor: The size of the grounding electrode conductor of a grounded or ungrounded AC system shall not be less than given in Table 250.66, except as permitted in *NEC 250.66(A)* through *(C)*.
 - 4.1.2 Connections to Concrete-Encased Electrodes: Where the grounding electrode is connected to a concrete-encased electrode as permitted in *NEC 250.52(A)(3)*, that portion of the conductor that is the sole connection to the grounding electrode shall not be required to be larger than 4AWG copper wire. *NEC 250.66(B)*
 - 4.1.3 Connections to Ground Rings: Where the grounding electrode conductor is connected to a ground ring as permitted in *250.52(A)(4)*, that portion of the conductor that is the sole connection to the grounding electrode shall not be required to be larger than the conductor used for the ground ring. *NEC 250.66(C)*
 - 4.1.4 Grounding electrode conductor shall be installed as specified in *NEC 250.64(A)* through *(F)*: Bare alum. or copper-clad alum. grounding conductors shall not be used in direct contact with masonry or the earth or where subject to corrosive conditions, and where used outside these conductors shall not be terminated within 18 in. of the earth. The grounding electrode shall be securely fastened to the surface on which it is carried. The grounding electrode shall be continuous, unless spliced by irreversible compression-type connectors.

Exception: Bus bars shall be permitted to connect together to form a grounding electrode. Metal enclosures for grounding electrode conductors shall be electrically continuous and securely fastened to ground clamp or fitting. The grounding electrode conductor can run to any convenient ground electrode or to each individually. The grounding electrode conductor shall be sized for the largest grounding electrode conductor among all the electrodes connected to it. **To provide protection from physical damage, grounding electrode conductors smaller than 6 AWG shall be installed in conduit.**

- 4.2 SAFETY BONDING: All piping and metal air ducts within the premises shall be bonded to provide additional safety. *NEC 205.104(A)(1) and 205.104(B)*

11

Table 250-66. Grounding Electrode Conductor for Alternating-Current Systems			
Size of Largest Ungrounded Service-Entrance Conductor or Equivalent Area for Parallel Conductors (AWG/kcmil)		Size of Grounding Electrode Conductor (AWG/kcmil)	
Copper	Aluminum or Copper-Clad Aluminum	Copper	Aluminum or Copper-Clad Aluminum
2 or smaller	1/0 or smaller	8	6
1 or 1/0	2/0 or 3/0	6	4
2/0 or 3/0	4/0 or 250 kcmil	4	2
Over 3/0 through 350 kcmil	Over 250 kcmil through 500 kcmil	2	1/0
Over 350 kcmil through 600 kcmil	Over 500 kcmil through 900 kcmil	1/0	3/0
Over 600 kcmil through 1100 kcmil	Over 900 kcmil through 1750 kcmil	2/0	4/0
Over 1100 kcmil	Over 1750 kcmil	3/0	250 kcmil

4.3 EQUIPMENT GROUNDING:

- 4.3.1 Metal raceways, cable trays, cable armor, cable sheath, enclosures, frames, fittings and other metal non-current-carrying parts that are to serve as grounding conductors, with or without the use of supplementary equipment grounding conductors, shall be effectively bonded where necessary to assure electrical continuity and the capacity to conduct safely any fault current likely to be imposed on them. Any nonconductive paint, enamel, or similar coating shall be removed at threads, contact points, and contact surfaces or be connected by means of fittings so designed as to make such removal unnecessary. *NEC 250.96(A)*
- 4.3.2 All receptacles installed on 15 and 20 ampere branch circuits shall be of the grounding type *NEC 406.3(A)*. General use snap switches shall be effectively grounded. *NEC 404.9(B)*
- 4.3.3 Surface Mounted Box: Where the box is mounted on the surface, direct metal-to-metal contact between the device yoke and the box shall be permitted to ground the receptacle and/or switch to the box or a contact yoke or device that complies with 250.146(B). This provision shall not apply to cover-mounted receptacles and/or switch unless the box and cover combination are listed as providing satisfactory ground continuity between the box and the receptacle and/or switch. *NEC 250.146(A), 404.9, 404.9(B)(1)*

- 4.3.4 Contact Devices or Yokes: Contact devices or yokes designed and listed as self-grounding shall be permitted in conjunction with the supporting screws to establish the grounding circuit between the device yoke and flush-type boxes. *NEC 250.146(B)*
- 4.3.5 Continuity and Attachment of Equipment Grounding Conductors to Boxes: Where circuit conductors are spliced within a box, or terminated on equipment within or supported by a box, any equipment grounding conductors associated with those circuit conductors shall be spliced or joined within the box or to the box with devices suitable for the use in accordance with *NEC 240.148(A) through (E)*. Connections depending solely on solder shall not be used. Splices shall be made in accordance with *NEC 110.14(B)* except that insulation shall not be required. The arrangement of grounding connections shall be such that the disconnection or the removal of a receptacle, luminaire, fixture or other device fed from the box does not interfere with or interrupt the grounding continuity. *NEC 250.148(E)*
- 4.3.6 Metal Boxes: A connection shall be made between the one or more equipment grounding conductors and a metal box by means of a grounding screw that shall be used for no other purpose or a listed grounding device. *NEC 250.148(A)*
- 4.4 GROUNDING ELECTRODE:
- 4.4.1 Electrodes of rods of iron or steel shall be at least 5/8 inch (15.87 mm) in diameter. Nonferrous or stainless steel rods or their equivalent less than 5/8 inch (15.87 mm) in diameter shall be listed and shall not be less than 1/2 inch (13 mm) in diameter. *NEC 250.52(A)(5b) and NEC TABLE 250.66*
- 4.4.2 Electrodes of pipe or conduit shall not be smaller than 3/4 inch trade size and, where of iron or steel, shall have the outer surface galvanized or otherwise metal-coated for corrosion protection. *NEC 250.52(A)(5a)*
- 4.4.3 The electrode shall be installed such that at least 8 feet (2.44 m) of length is in contact with the soil. It shall be driven to a depth of not less than 8 feet (2.44 m) except that where rock bottom is encountered the electrode shall be driven at an oblique angle not to exceed 45 degrees from the vertical or shall be buried in a trench that is at least 30 inches (750 mm) deep. The upper end of the electrode shall be flush with or below ground level unless the aboveground end and the grounding electrode conductor attachment are protected against physical damage as specified in *NEC 250.10, NEC 252.53(G)*
- 4.4.4 A single electrode consisting of a rod, pipe, or plate, which does not have a resistance to ground of 25 ohms or less, shall be augmented by one additional electrode. Where multiple rod, pipe, or plate electrodes are installed they shall be not less than 6 feet (1.83 m) apart. *NEC 250.56*

5. PROTECTIVE EQUIPMENT

- 5.1 APPROVAL: All service equipment shall be approved for the purpose used and the solid-neutral type, where a neutral is present. Such protective equipment shall be protected from mechanical injury and shall not be located in the vicinity of easily ignitable materials.
- 5.2 LOCATION:
- 5.2.1 General: Means shall be provided to disconnect all conductors in a building or other structure from the service-entrance conductors. *NEC 230.70*
- 5.2.2 Location: The service disconnecting means shall be installed in accordance with NEC 230.70(A)(1), (2), and (3).
- Readily Accessible Location: The service disconnecting means shall be installed at a readily accessible location either outside of a building or structure or inside nearest the point of entrance of the service conductors. *NEC 230.70(A)(1)*
- Bathrooms: Service disconnecting means shall not be installed in bathrooms. *NEC 230.70(A)(2)*
- Remote Control: Where a remote control device is used to actuate the service disconnecting means, the service disconnecting means shall be located in accordance with NEC 230.70(A)(1).
- 5.2.3 Marking: Each service disconnect shall be permanently marked to identify it as a service disconnect.
- 5.2.4 Each service disconnecting means shall be suitable for the prevailing conditions. Service equipment installed in hazardous (classified) locations shall comply with the requirements of Articles 500 through 517.
- 5.2.5 Hazardous Locations:
- Not in Vicinity of Easily Ignitable Material. Overcurrent devices shall not be located in the vicinity of easily ignitable material, such as in clothes closets. *NEC 240.24(D)*
- Not Located in Bathrooms. In dwelling units and guest rooms or guest suites of hotels and motels, overcurrent devices, other than supplementary overcurrent protection, shall not be located in bathrooms. *NEC 240.24(E)*
- 5.2.6 Please contact your local utility or authority of jurisdiction prior to electrical construction as these electrical requirements may vary.

5.3 MOUNTING OF EQUIPMENT: (OSHA)

- 5.3.1 Protection from Physical Damage. Overcurrent devices shall be protected from physical damage by one of the following:
- Installation in enclosures, cabinets, cutout boxes, or equipment assemblies.
- Mounting on open-type switchboards, panelboards, or control boards that are in rooms or enclosures free from dampness and easily ignitable material and are accessible only to qualified personnel. *NEC 240.30(A)*
- 5.3.2 Damp Or Wet Locations: Enclosures for overcurrent devices in damp or wet locations shall comply with 312.2. Refer to definition of Location, damp or Location, wet. *Article 100*
- 5.3.3 Vertical Positions: Enclosures for overcurrent devices shall be mounted in a vertical position unless that is shown to be impracticable. Circuit breaker enclosures shall be permitted to be installed horizontally where the circuit breaker is installed in accordance with 240.81. Listed busway plug-in units shall be permitted to be mounted in orientations corresponding to the busway mounting position. *NEC 240.33*
- 5.4 MARKING OF EQUIPMENT:
- 5.4.1 Marking: The manufacturer's name, trademark, or other descriptive marking by which the organization responsible for the product can be identified shall be placed on all electric equipment. Other markings that indicate voltage, current, wattage, or other ratings shall be provided as specified elsewhere in this Code. The marking shall be of sufficient durability to withstand the environment involved. *NEC 110.21*
- Each disconnecting means shall be legibly marked to indicate its purpose unless located and arranged so the purpose is evident. The marking shall be of sufficient durability to withstand the environment involved. *NEC 110.22*
- 5.4.2 Identification of Disconnecting Means: Where circuit breakers or fuses are applied in compliance with the series combination ratings marked on the equipment by the manufacturer, the equipment enclosure(s) shall be legibly marked in the field to indicate the equipment has been applied with a series combination rating. The marking shall be readily visible and state the following:
- CAUTION — SERIES COMBINATION SYSTEM RATED ___ AMPERES. IDENTIFIED REPLACEMENT COMPONENTS REQUIRED. *NEC 110.22***
- 5.4.3 FPN: See Section 240.86(B) for interrupting rating marking for end-use equipment.

5.5 OVERCURRENT PROTECTION (Fuses or Breakers):

5.5.1 The basic purpose of overcurrent protection is to open the circuit before conductors or the conductor insulation are damaged when an overcurrent condition occurs. An overcurrent condition can be the result of an overload, ground fault, or a short circuit and must be eliminated before the conductor insulation damage point is reached.

FPN: A current in excess of rating may be accommodated by certain equipment and conductors for a given set of conditions. Therefore, the rules for overcurrent protection are specific for particular situations.

5.5.2 Overcurrent protection for conductors and equipment is provided to open the circuit if the current reaches a value that will cause an excessive or dangerous temperature in conductors or conductor insulation. *NEC 240.1*

Definition of overcurrent: Any current in excess of the rated current of equipment or the ampacity of a conductor. It may result from overload, short circuit, or ground fault. *NEC Article 100*

Overcurrent protective devices, such as fuses and circuit breakers, should be selected in a manner that ensures the short-circuit withstand rating of the system components will not be exceeded should a short circuit or high-level ground fault occur.

6. BRANCH CIRCUIT WIRING

6.1 LENGTH OF FREE CONDUCTORS AT OUTLETS, JUNCTIONS, AND SWITCH POINTS:

6.1.1 At least 150 mm (6 in.) of free conductor, measured from the point in the box where it emerges from its raceway or cable sheath, shall be left at each outlet, junction, and switch point for splices or the connection of luminaires (fixtures) or devices.

6.1.2 Where the opening to an outlet, junction, or switch point is less than 200 mm (8 in.) in any dimension, each conductor shall be long enough to extend at least 75 mm (3 in.) outside the opening. *NEC 300.14*

6.1.3 *Exception: Conductors that are not spliced or terminated at the outlet, junction, or switch point shall not be required to comply with 300.14.*

6.2 MECHANICAL AND ELECTRICAL CONTINUITY — CONDUCTORS:

6.2.1 General: Conductors in raceways shall be continuous between outlets, boxes, devices, and so forth. There shall be no splice or tap within a raceway unless permitted by 300.15; 368.8(A); 376.56; 378.56; 384.56; 386.56; 388.56; or 390.6. *NEC 300.13(A)*

6.2.2 Device Removal: In multiwire branch circuits, the continuity of a grounded conductor shall not depend on device connections such as lamp holders, receptacles, and so forth, where the removal of such devices would interrupt the continuity. *NEC 300.13(B)*

6.3 SPLICES:

6.3.1 Conductors shall be spliced or joined with splicing devices identified for the use or by brazing, welding, or soldering with a fusible metal or alloy. Soldered splices shall first be spliced or joined so as to be mechanically and electrically secure without solder and then soldered. All splices and joints and the free ends of conductors shall be covered with insulation equivalent to that of the conductors or with an insulating device identified for the purpose. *NEC 110.14(B)*

6.3.2 Where circuit conductors are spliced within a box, or terminated on equipment within or supported by a box, any separate equipment grounding conductors associated with those circuit conductors shall be spliced or joined within the box or to the box with devices suitable for the use in accordance with *NEC 250.148(A)* through (E).

6.3.3 A box or fitting shall be installed at each conductor splice, connection point, outlet point, switch point, junction point termination point, or pull point unless otherwise permitted in *NEC 300.15(A)* through (M).

6.4 CIRCUIT IDENTIFICATION: Each branch circuit shall be specifically identified on the service panel directory provided by the manufacturer. *NEC 110.22*

6.5 CABLE CLAMPS AND CONNECTORS:

6.5.1 Conductors entering boxes, conduit bodies, or fittings shall be protected from abrasion. Openings through which conductors enter shall be adequately closed.

6.5.2 Where raceway or cable is installed with metal boxes or conduit bodies, the raceway or cable shall be secured to such boxes and conduit bodies.

6.5.3 Non-metallic boxes and conduit bodies shall be suitable for the lowest temperature-rated conductor entering the box. Where nonmetallic-sheathed cable or multiconductor Type UF cable is used, the sheath shall extend not less than 6 mm (1/4 in.) inside the box and beyond any cable clamp. In all instances, all permitted wiring methods shall be secured to the boxes. *NEC 314.17(A)(B)(C)*

6.6 NON-METALLIC-SHEATHED CABLE: This cable shall be supported and secured by staples, cable ties, hangers, straps, or similar fittings designed and installed so as not to damage the cable, at intervals not exceeding 4 1/2 feet (1.4 m) and within 12 inches

(300 mm) of every outlet box, junction box, cabinet or fitting. Flat cable shall not be stapled on edge. *NEC 334.30*

- 6.7 **KNOCKOUT CLOSERS:** Unused cable or raceway openings in boxes, conduit bodies, and fittings shall be effectively closed to afford protection substantially equivalent to that of the wall of the box, conduit body, or fitting. Metal plugs or plates used with nonmetallic boxes, conduit bodies, or fittings shall be recessed at least 1/4 inch (6.0 mm) from the outer surface. *NEC 110.12(A)*
- 6.8 **GENERAL PURPOSE OUTLETS:**
- 6.8.1 **Grounding Type:** Receptacles installed on 15- and 20-ampere branch circuits shall be of the grounding type. Grounding-type receptacles shall be installed only on circuits of the voltage class and current for which they are rated, except as provided in Table 210.21(B)(2) and (B)(3) *NEC 406.3(A)*.
Exception: Non-grounding-type receptacles installed in accordance with 406.3(D).
- 6.8.2 For receptacle outlets, each single or each multiple receptacle on one strap shall be considered at not less than 180 volt-amperes. The number of outlets permitted on 15 and 20-ampere branch circuits shall be calculated using 180 VA rating per receptacle outlet. *NEC.220.14(I)*
- 6.9 **SMALL APPLIANCE CIRCUITS:** *NEC 210.11*
- 6.9.1 **Branch Circuit Required:** Branch circuits for lighting, and for lighting and appliances, including motor-operated appliances, shall be provided to supply the loads computed in accordance with 220.10. In addition, branch circuits shall be provided for specific loads not covered by 220.10 where required elsewhere in this Code and for dwelling unit loads as specified in 210.11.

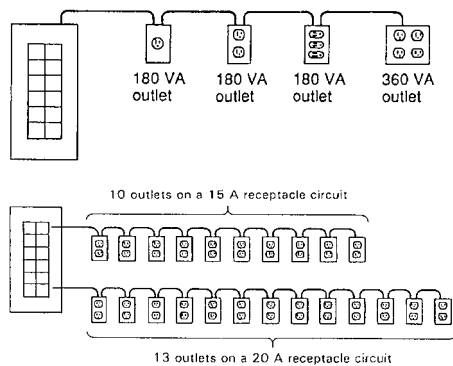

15 amperes × 120 volts = 1800 VA ÷ 180 VA = 10 receptacle outlets
 20 amperes × 120 volts = 2400 VA ÷ 180 VA = 13 receptacle outlets

18

19

- 6.9.2 **Number Of Branch Circuits:** The minimum number of branch circuits shall be determined from the total computed load and the size of rating of the circuits used. In all installations, the number of circuits shall be sufficient to supply the load served. In no case shall the load on any circuit exceed the maximum specified by 220.18. *NEC 210.11(A)*
- 6.9.3 **Load Evenly Proportioned Among Branch Circuits:** Where the load is calculated on a volt-amperes/square meter or per square foot, the wiring system up to and including the branch-circuit panelboard(s) shall be provided to serve not less than the calculated load. This load shall be evenly proportioned among multioutlet branch circuits within the panelboard(s). Branch-circuit-overcurrent devices and circuits shall only be required to be installed to serve the connected load. *NEC 210.11(B)*
- 6.9.4 **Dwelling Units:**

SMALL APPLIANCE BRANCH CIRCUITS

In addition to the number of branch circuits required by other parts of this section, two or more 20-ampere small-appliance branch circuits shall be provided for all receptacle outlets specified by 210.52(B). *NEC 210.11(C)(1)*

LAUNDRY BRANCH CIRCUITS

In addition to the number of branch circuits required by other parts of this section, at least one additional 20-ampere branch circuit shall be provided to supply the laundry receptacle outlet(s) required by 210.52(F). This circuit shall have no other outlets. *NEC 210.11(C)(2)*

BATHROOM BRANCH CIRCUITS

In addition to the number of branch circuits required by other parts of this section, at least one 20-ampere branch circuit shall be provided to supply bathroom receptacle outlet(s). Such circuits shall have no other outlets. *NEC 210.11(C)(3)*

Exception: Where the 20-ampere circuit supplies a single bathroom, outlets for other equipment within the same bathroom shall be permitted to be supplied in accordance with 210.23(A)(1) and (A)(2).

FPN: See Examples D1(A), D1(B), D2(B), and D4(A) in Annex D.

6.10 DWELLING UNIT RECEPTACLE OUTLETS: NEC 210.52

This section provides requirements for 125-volt, 15- and 20-ampere receptacle outlets. Receptacle outlets required by this section shall be in addition to any receptacle that is part of a luminaire (lighting fixture) or appliance, located within cabinets or cupboards, or located more than 1.7 m (5 1/2 ft) above the floor.

Permanently installed electric baseboard heaters equipped with factory-installed receptacle outlets or outlets provided as a separate

assembly by the manufacturer shall be permitted as the required outlet or outlets for the wall space utilized by such permanently installed heaters. Such receptacle outlets shall not be connected to the heater circuits. *NEC 210.52*

FPN: Listed baseboard heaters include instructions that may not permit their installation below receptacle outlets.

- 6.10.1 General Provisions: In every kitchen, family room, dining room, living room, parlor, library, den, sunroom, bedroom, recreation room, or similar room or area of dwelling units, receptacle outlets shall be installed in accordance with the general provisions specified in 210.52(A)(1) through (A)(3).
SPACING. Receptacles shall be installed so that no point measured horizontally along the floor line in any wall space is more than 1.8 m (6 ft) from a receptacle outlet.

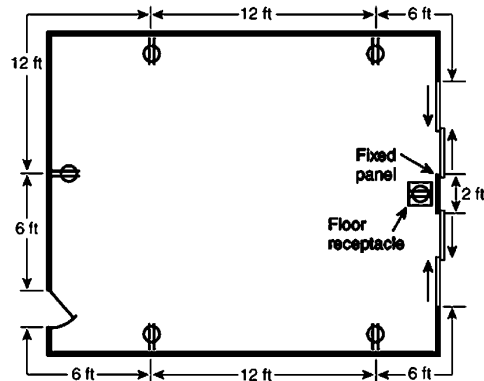

Exhibit 210.24 Typical room plan view of the location of dwelling unit receptacles meeting the requirements of 210.52(A).

WALL SPACE. As used in this section, a wall space shall include the following:

Any space 600 mm (2 ft) or more in width (including space measured around corners) and unbroken along the floor line by doorways, fireplaces, and similar openings.

The space occupied by fixed panels in exterior walls, excluding sliding panels.

The space afforded by fixed room dividers such as freestanding bar-type counters or railings.

FLOOR RECEPTACLES. Receptacle outlets in floors shall not be counted as part of the required number of receptacle outlets unless located within 450 mm (18 in.) of the wall.

- 6.10.2 Small Appliance Branch Circuits: Receptacle outlets in the kitchen, pantry, breakfast room, dining room, or similar area of a dwelling unit, the two or more 20-ampere small-appliance branch circuits required

by 210.11(C)(1) shall serve all wall and floor receptacle outlets covered by 210.52(A), all countertop outlets covered by 210.52(C), and receptacle outlets for refrigeration equipment. *NEC 210.52.(B)(1)*

Exception No. 1: In addition to the required receptacles specified by 210.52, switched receptacles supplied from a general-purpose branch circuit as defined in 210.70(A)(1), Exception No. 1, shall be permitted.

Exception No. 2: The receptacle outlet for refrigeration equipment shall be permitted to be supplied from an individual branch circuit rated 15 amperes or greater.

NO OTHER OUTLETS

The two or more small-appliance branch circuits specified in 210.52(B)(1) shall have no other outlets.

Exception No. 1: A receptacle installed solely for the electrical supply to and support of an electric clock in any of the rooms specified in 210.52(B)(1).

Exception No. 2: Receptacles installed to provide power for supplemental equipment and lighting on gas-fired ranges, ovens, or counter-mounted cooking units.

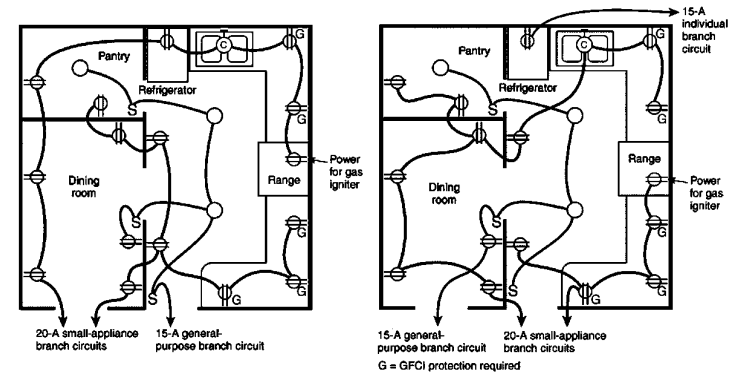

Exhibit 210.25 Small-appliance branch circuits as applied to the requirements of 210.52(B)(1), (2), and (3) for all receptacle outlets in the kitchen (including refrigerator), pantry, and dining room.

KITCHEN RECEPTACLE REQUIREMENTS

Receptacles installed in a kitchen to serve countertop surfaces shall be supplied by not fewer than two small-appliance branch circuits, either or both of which shall also be permitted to supply receptacle outlets in the same kitchen and in other rooms specified in 210.52(B)(1). Additional small-appliance branch circuits shall be permitted to supply receptacle outlets in the kitchen and other rooms specified in 210.52(B)(1). No small-appliance branch circuit shall serve more than one kitchen.

6.10.3 Countertops: In kitchens and dining rooms of dwelling units, receptacle outlets for counter spaces shall be installed in accordance with 210.52(C)(1) through (5).

Exception No. 1: Receptacle outlets shall not be required on a wall directly behind a range or sink in the installation described in figure 210.25 of the NEC.

Exception No. 2: Sinks or rangetops as covered in 210.52(C)(1), exception, or appliances occupying dedicated space shall not be considered as these required outlets. NEC 210.52(C)(5)

(See Exhibit 210.25 on previous page.)

WALL COUNTER SPACES

A receptacle outlet shall be installed at each wall counter space that is 300 mm (12 in.) or wider. Receptacle outlets shall be installed so that no point along the wall line is more than 600 mm (24 in.) measured horizontally from a receptacle outlet in that space.

ISLAND COUNTER SPACES

At least one receptacle outlet shall be installed at each island counter space with a long dimension of 600 mm (24 in.) or greater and a short dimension of 300 mm (12 in.) or greater. NEC 210.52.(B)(2)

PENINSULAR COUNTER SPACES

At least one receptacle outlet shall be installed at each peninsular counter space with a long dimension of 600 mm (24 in.) or greater and a short dimension of 300 mm (12 in.) or greater. A peninsular countertop is measured from the connecting edge. NEC 210.52.(B)(3)

Countertop spaces separated by range tops, refrigerators, or sinks shall be considered as separate countertop spaces in applying the requirements of 210.52(C)(1), (2), and (3).

RECEPTACLE OUTLET LOCATION

Receptacle outlets shall be located above, but not more than 500 mm (20 in.) above, the countertop. Receptacle outlets rendered not readily accessible by appliances fastened in place, appliance garages, sinks or rangetops as covered in 210.52(C)(1), exception, or appliances occupying dedicated space shall not be considered as these required outlets. NEC 210.52.(C)(5)

Exception: To comply with the conditions specified in (a) or (b), receptacle outlets shall be permitted to be mounted not more than 300 mm (12 in.) below the countertop. Receptacles mounted below a countertop in accordance with this exception shall not be located where the countertop extends more than 150 mm (6 in.) beyond its support base.

(a) Construction for the physically impaired.

(b) On island and peninsular countertops where the countertop is flat across its entire surface (no backsplashes, dividers, etc.) and there are no means to mount a receptacle within 500 mm (20 in.) above the countertop, such as an overhead cabinet.

BATHROOMS

In dwelling units, at least one wall receptacle outlet shall be installed in bathrooms within 900 mm (3 ft.) of the outside edge of each basin. The receptacle outlet shall be located on a wall or partition that is adjacent to the basin or basin countertop. NEC 210.52(D)
Exception: The receptacle shall not be required to be mounted in the wall or partition where it is installed on the side or face of the basin cabinet not more than 300 mm (12 in) below the countertop. 210.52(B)(1).

OUTDOOR OUTLETS

For a one-family dwelling and each unit of a two-family dwelling that is at grade level, at least one receptacle outlet accessible at grade level and not more than 2.0 m (6 1/2 ft.) above grade shall be installed at the front and back of the dwelling. See 210.8(A)(3).

LAUNDRY AREAS

In dwelling units, at least one receptacle outlet shall be installed for the laundry.

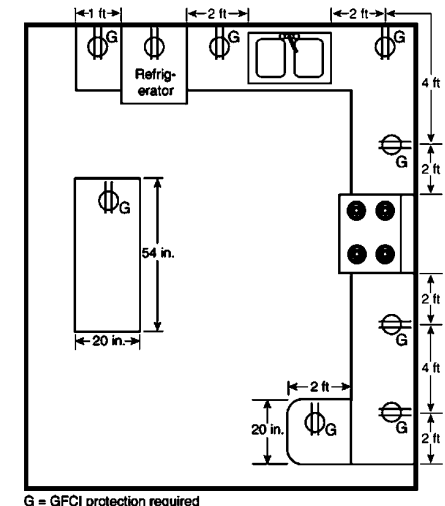

Exhibit 210.26 Dwelling unit receptacles serving countertop spaces in a kitchen and installed in accordance with 210.52(C).

Exception No. 1: In a dwelling unit that is an apartment or living area in a multifamily building where laundry facilities are provided on the premises and are available to all building occupants, a laundry receptacle shall not be required.

Exception No. 2: In other than one-family dwellings where laundry facilities are not to be installed or permitted, a laundry receptacle shall not be required.

BASEMENTS AND GARAGES

For a one-family dwelling, at least one receptacle outlet, in addition to any provided for laundry equipment, shall be installed in each basement and in each attached garage, and in each detached garage with electric power. See 210.8(A)(2) and (A)(5). Where a portion of the basement is finished into one or more habitable rooms, each separate unfinished portion shall have a receptacle outlet installed in accordance with this section.

HALLWAYS

In dwelling units, hallways of 3.0 m (10 ft.) or more in length shall have at least one receptacle outlet. As used in this subsection, the hall length shall be considered the length along the centerline of the hall without passing through a doorway.

- 6.11 GROUND-FAULT CIRCUIT-INTERRUPTER PROTECTION FOR PERSONNEL: All 15 and 20 ampere receptacles installed in bathrooms, garages, and outdoors, crawl space and within six feet of kitchen sinks shall have ground-fault circuit interrupter protection for personnel. *NEC 210.8*

FPN: See 215.9 for ground-fault circuit-interrupter protection for personnel on feeders.

- 6.11.1 Dwelling Units: All 125-volt, single-phase, 15- and 20-ampere receptacles installed in the locations specified in (1) through (8) shall have ground-fault circuit-interrupter protection for personnel.

(1) Bathrooms.

(2) Garages and also accessory buildings that have a floor located at or below grade level not intended as habitable rooms and limited to storage areas, work areas, and areas of similar use.

Exception No. 1 to (2): Receptacles that are not readily accessible.

Exception No. 2 to (2): A single receptacle or a duplex receptacle for two appliances located within dedicated space for each appliance that, in normal use, is not easily moved from one place to another and that is cord-and-plug connected in accordance with NEC 400.7(A)(6), (A)(7), or (A)(8).

Receptacles installed under the exceptions to 210.8(A)(2) shall not be considered as meeting the requirements of 210.52(G).

(3) Outdoors.

Exception to (3): Receptacles that are not readily accessible and are supplied by a dedicated branch circuit for electric snow-melting or deicing equipment shall be permitted to be installed in accordance with the applicable provisions of Article 426.28.

(4) Crawl Spaces at or below grade level

(5) Unfinished Basements. For purposes of this section, unfinished basements are defined as portions or areas of the basement not intended as habitable rooms and limited to storage areas, work areas, and the like.

Exception No. 1 to (5): Receptacles that are not readily accessible.

Exception No. 2 to (5): A single receptacle or a duplex receptacle for two appliances located within dedicated space for each appliance that, in normal use, is not easily moved from one place to another and that is cord-and-plug connected in accordance with 400.7(A)(6), (A)(7), or (A)(8).

Exception No. 3 to (5): A receptacle supplying only a permanently installed fire alarm or burglar alarm system shall not be required to have ground-fault circuit-interrupter protection. Receptacles installed under the exceptions to 210.8(A)(5) shall not be considered as meeting the requirements of 210.52(G).

(6) Kitchens where the receptacles are installed to serve the countertop surfaces.

(7) Laundry, utility, and wet bar sinks where the receptacles are installed within 1.8 m (6 ft.) of the outside edge of the wet bar sink.

(8) Boathouses.

- 6.11.2 Other Than Dwelling Units: All 125-volt, single-phase, 15- and 20-ampere receptacles installed in the locations specified in (1) through (5) shall have ground-fault circuit-interrupter protection for personnel:

(1) Bathrooms.

(2) Commercial and institutional kitchens

(3) Rooftops.

(4) Outdoors in public spaces

(5) Outdoors, where installed to comply with 210.63

Exception to (3) and (4): Receptacles that are not readily accessible and are supplied from a dedicated branch circuit for electric snow-melting or deicing equipment shall be permitted to be installed in accordance with the applicable provisions of Article 426.

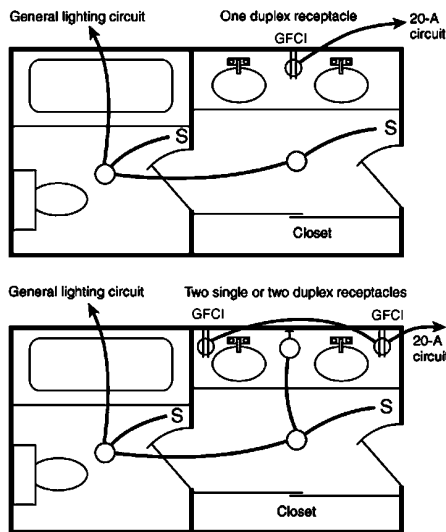

26 **Exhibit 210.9 GFCI-protected receptacles in accordance with 210.8(A)(1) in bathrooms.**

6.12 **ARC-FAULT CIRCUIT INTERRUPTER PROTECTION:**
NEC 210.12

6.12.1 **Definition:** An arc-fault circuit interrupter is a device intended to provide protection from the effects of arc faults by recognizing characteristics unique to arcing and by functioning to de-energize the circuit when an arc fault is detected.

6.12.2 **Dwelling Unit Bedrooms:** All 120-volt, single phase, 15- and 20-ampere branch circuits supplying outlets installed in dwelling unit bedrooms shall be protected by a listed arc-fault circuit interrupter, combination type installed listed to provide protection of the branch circuit.

Exception: The location of the arc-fault circuit interrupter shall be permitted to be at other than the origination of the branch circuit in compliance with (a) and (b):

- (a) *The arc-fault circuit interrupter installed within 1.8 m (6 ft.) of the branch circuit overcurrent device as measured along the branch circuit conductors.*
- (b) *The circuit conductors between the branch circuit overcurrent device and the arc-fault circuit interrupter shall be installed in a metal raceway or a cable with a metallic sheath.*

6.13 **BOXES:**

6.13.1 **Round Boxes:** Round boxes shall not be used where conduits or connectors requiring the use of locknuts or bushings are to be connected to the side of the box. *NEC 314.2*

6.13.2 **Nonmetallic Boxes:** Nonmetallic boxes shall be permitted only with open wiring on insulators, concealed knob-and-tube wiring, cabled wiring methods with entirely nonmetallic sheaths, flexible cords, and nonmetallic raceways. *NEC 314.3*

Exception No. 1: Where internal bonding means are provided between all entries, nonmetallic boxes shall be permitted to be used with metal raceways or metal-armored cables.

Exception No. 2: Where integral bonding means with a provision for attaching an equipment bonding jumper inside the box are provided between all threaded entries in nonmetallic boxes listed for the purpose, nonmetallic boxes shall be permitted to be used with metal raceways or metal-armored cables.

6.14 **NUMBER OF CONDUCTORS IN OUTLET, DEVICE, AND JUNCTION BOXES, AND CONDUIT BODIES:** *NEC 314.16*

Boxes and conduit bodies shall be of sufficient size to provide free space for all enclosed conductors. In no case shall the volume of the box, as calculated in 314.16(A), be less than the fill calculation as calculated in 314.16(B). The minimum volume for conduit bodies shall be as calculated in 314.16(C). The provisions of this section shall not apply to terminal housings supplied with motors. *NEC 314.16*

FPN: For volume requirements of motor terminal housings, see 430.12.

Boxes and conduit bodies enclosing conductors 4 AWG or larger shall also comply with the provisions of 314.28.

6.14.1 **Box Volume Calculations:** The volume of a wiring enclosure (box) shall be the total volume of the assembled sections, and, where used, the space provided by plaster rings, domed covers, extension rings, and so forth, that are marked with their volume or are made from boxes the dimensions of which are listed in Table 314.16(A).

Standard Boxes. The volumes of standard boxes that are not marked with their volume shall be as given in Table 314.16(A).

Other Boxes. Boxes 1650 cm³ (100 in.³) or less, other than those described in Table 314.16(A), and nonmetallic boxes shall be durably and legibly marked by the manufacturer with their volume. Boxes described in Table 314.16(A) that have a volume larger than is designated in the table shall be permitted to have their volume marked as required by this section.

6.14.2 **Box Fill Calculations:** The volumes in paragraphs 314.16(B)(1) through (5), as applicable, shall be added together. No allowance shall be required for small fittings such as locknuts and bushings.

Conductor Fill. Each conductor that originates outside the box and terminates or is spliced within the box shall be counted once, and

each conductor that passes through the box without splice or termination shall be counted once. A looped, unbroken conductor not less than twice the minimum length required for free conductors in 300.14 shall be counted twice. The conductor fill shall be computed using Table 314.16(B). A conductor, no part of which leaves the box, shall not be counted.

Exception: An equipment grounding conductor or conductors or not over 4 luminaire (fixture) wires smaller than 14 AWG, or both, shall be permitted to be omitted from the calculations where they enter a box from a domed luminaire (fixture) or similar canopy and terminate within that box.

Clamp Fill. Where one or more internal cable clamps, whether factory or field supplied, are present in the box, a single volume allowance in accordance with Table 314.16(B) shall be made based on the largest conductor present in the box. No allowance shall be required for a cable connector with its clamping mechanism outside the box.

Support Fittings Fill. Where one or more luminaire (fixture) studs or hickies are present in the box, a single volume allowance in accordance with Table 314.16(B) shall be made for each type of fitting based on the largest conductor present in the box.

Device or Equipment Fill. For each yoke or strap containing one or more devices or equipment, a double volume allowance in accordance with Table 314.16(B) shall be made for each yoke or strap based on the largest conductor connected to a device(s) or equipment supported by that yoke or strap.

Equipment Grounding Conductor Fill. Where one or more equipment grounding conductors or equipment bonding jumpers enter a box, a single volume allowance in accordance with Table 314.16(B) shall be made based on the largest equipment grounding conductor or equipment bonding jumper present in the box. Where an additional set of equipment grounding conductors, as permitted by 250.146(D), is present in the box, an additional volume allowance shall be made based on the largest equipment grounding conductor in the additional set.

Table 314.16(B) Volume Allowance Required Per Conductor

Size of Conductor (AWG)	Free Space Within Box for Each Conductor	
	cm ³	in. ³
18	24.6	1.50
16	28.7	1.75
14	32.8	2.00
12	36.9	2.25
10	41.0	2.50
8	49.2	3.00
6	81.9	5.00

Table 314.16(A) Metal Boxes

Box Trade Size			Minimum Volume		Maximum Number of Conductors*						
			cm ³	in. ³	18	16	14	12	10	8	6
100 × 32	(4 × 1¼)	round/octagonal	205	12.5	8	7	6	5	5	5	2
100 × 38	(4 × 1½)	round/octagonal	254	15.5	10	8	7	6	6	5	3
100 × 54	(4 × 2½)	round/octagonal	353	21.5	14	12	10	9	8	7	4
100 × 32	(4 × 1¼)	square	295	18.0	12	10	9	8	7	6	3
100 × 38	(4 × 1½)	square	344	21.0	14	12	10	9	8	7	4
100 × 54	(4 × 2½)	square	497	30.3	20	17	15	13	12	10	6
120 × 32	(4½ × 1¼)	square	418	25.5	17	14	12	11	10	.8	5
120 × 38	(4½ × 1½)	square	484	29.5	19	16	14	13	11	9	5
120 × 54	(4½ × 2½)	square	689	42.0	28	24	21	18	16	14	8
75 × 50 × 38	(3 × 2 × 1½)	device	123	7.5	5	4	3	3	3	2	1
75 × 50 × 50	(3 × 2 × 2)	device	164	10.0	6	5	5	4	4	3	2
75 × 50 × 57	(3 × 2 × 2¼)	device	172	10.5	7	6	5	4	4	3	2
75 × 50 × 65	(3 × 2 × 2½)	device	205	12.5	8	7	6	5	5	4	2
75 × 50 × 70	(3 × 2 × 2¾)	device	230	14.0	9	8	7	6	5	4	2
75 × 50 × 90	(3 × 2 × 3½)	device	295	18.0	12	10	9	8	7	6	3
100 × 54 × 38	(4 × 2½ × 1½)	device	169	10.3	6	5	5	4	4	3	2
100 × 54 × 48	(4 × 2½ × 1¾)	device	213	13.0	8	7	6	5	5	4	2
100 × 54 × 54	(4 × 2½ × 2½)	device	238	14.5	9	8	7	6	5	4	2
95 × 50 × 65	(3¼ × 2 × 2½)	masonry box/gang	230	14.0	9	8	7	6	5	4	2
95 × 50 × 90	(3¼ × 2 × 3½)	masonry box/gang	344	21.0	14	12	10	9	8	7	2
min. 44.5 depth	FS — single cover/gang (1¾)		221	13.5	9	7	6	6	5	4	2
min. 60.3 depth	FD — single cover/gang (2¾)		295	18.0	12	10	9	8	7	6	3
min. 44.5 depth	FS — multiple cover/gang (1¾)		295	18.0	12	10	9	8	7	6	3
min. 60.3 depth	FD — multiple cover/gang (2¾)		395	24.0	16	13	12	10	9	8	4

*Where no volume allowances are required by 314.16(B)(2) through 314.16(B)(5).

6.14.3 **Metal Boxes:** All metal boxes shall be grounded in accordance with the provisions of Article 250. See equipment grounding section in manual 250.148(A). A connection shall be made between the one or more equipment grounding conductors and a metal box by means of a grounding screw that shall be used for no other purpose or a listed grounding device. *NEC 250.148(A) through (E)*

6.14.4 **Connecting Receptacle Grounding Terminal to Box:** An equipment-bonding jumper shall be used to connect the grounding terminal of a grounding type receptacle to a grounded box. A grounding clip (EMC diagrams 1 and 2) or screw as shown (EMC diagrams 3 and 4) may be used to connect grounding conductor to a box. *NEC 250-146(A) through (D)*

6.14.5 Where the box is surface mounted, direct metal-to-metal contact between the device yoke that complies with 250.146(B) and the box shall be permitted to ground the receptacle and/or switch to a grounded box. At least one of the insulating washers shall be removed from the receptacle that do not have a contact yoke or device that complies with 250.146(B) to ensure direct metal to metal contact. This provision shall not apply to cover-mounted receptacles and/or switches (such as a 4-inch square box) unless the box and cover combination are listed as providing satisfactory ground continuity between the box and the receptacle and/or switch. *NEC 250.146(A) and NEC 404.9*

EMC DIAGRAM 1.

Flush-Type Boxes. Receptacle designed with spring-type grounding strap which holds mounting screw captive and eliminates a bonding jumper to the box.

**PROPER INSTALLATION OF BOND WIRES
(Bonding screws or clips may be used.)**

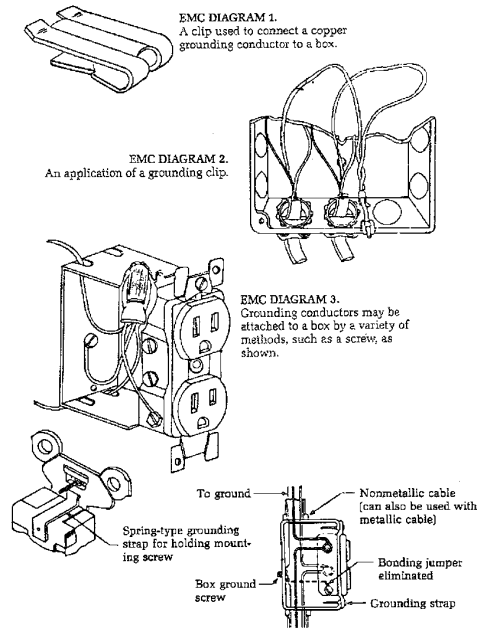

6.15 CONDUIT:

6.15.1 Conduit Uses:

Rigid Conduit. The use of rigid metal conduit shall be permitted under all atmospheric conditions and occupancies subject to NEC 344 and NEC 300-6.

Rigid Nonmetallic Conduit. The use of rigid nonmetallic conduit and fittings shall be permitted subject to NEC 352.10 (A) through (H) and NEC 300-6.

Electrical Metallic Tubing. The use of electrical metallic tubing shall be permitted for both exposed and concealed work subject to NEC 358 and NEC 300-6.

Flexible Metallic Tubing. The use of flexible metallic tubing shall be permitted subject to NEC 360 and NEC 300-6.

Flexible Metal Conduit. The use of flexible metal conduit shall be permitted subjected to NEC 348 and NEC 300-6.

Liquid-Tight Flexible Metal Conduit and Liquid-Tight Flexible Nonmetallic Conduit. The use of liquid-tight flexible metal conduit

and liquid-tight flexible nonmetallic conduit shall be permitted subject to NEC 350, NEC 356, and NEC 300-6.

Electrical Nonmetallic Tubing. The use of electrical nonmetallic tubing shall be permitted subject to NEC 362 and NEC 300-6.

- 6.15.2 No run of conduit shall have more than the equivalent of 4 quarter bends (360 degrees). *NEC 344.26, 348.24, 350.26, 352.26, 356.26, 358.26*
- 6.15.3 Metallic and nonmetallic water pipe is not approved for use as conduit.
- 6.15.4 Conduit shall be used to protect surface runs of cables on floors or walls. Where subject to severe physical damage, only rigid metal conduit should be used.
- 6.15.5 To determine the maximum number of conductors allowed in conduit refer to NEC Annex C.

7. LIGHT CIRCUIT WIRING

7.1 LIGHTING OUTLETS REQUIRED:

At least one wall switch controlled lighting outlet shall be installed in every habitable room; in bathrooms, hallways, stairways, attached garages, and detached garages with electric power; and at outdoor entrances or exits. *NEC 210.70*

A vehicle door in an attached garage is not considered an outdoor entrance or exit. *NEC 210.70(2)(B)*

At least one lighting outlet controlled by a light switch located at the point of entry to the attic, under floor space, utility room, and basement shall be installed only where these spaces are used for storage or containing equipment requiring servicing. The lighting outlet shall be provided at or near the equipment requiring servicing. *NEC 210.70*

A receptacle controlled by a wall switch shall be permitted in lieu of lighting outlet. Also, in hallways, stairways, and at outdoor entrances, remote control or automatic control of lighting shall be permitted. *NEC 210.70*

INSTALLATION: All wiring for lighting circuits shall be installed in approved-type boxes. This wiring shall enter boxes through approved type raceways, connectors, or clamps. Conductors may be in rigid conduit, EMT, nonmetallic conduit, or nonmetallic sheathed cable. Switches controlling the lighting shall not disconnect the grounded conductor of the circuit. At least 6 inches (152 mm) of free conductor shall be left at each outlet, junction, and switch point for splices or the connection of fixtures or devices. All incandescent lights shall be polarized. The grounded conductor shall be connected to the shell of the light socket. The ungrounded

conductor shall be connected to the center contact of the socket.
NEC 300.14, 15; 404.2(B), and 410.23

7.2 FIXTURES IN CLOTHES CLOSET:

(A) Definition: *NEC 410.8(A)*

Storage space shall be defined as a volume bounded by the sides and back closet walls and planes extending from the closet floor vertically to a height of 6 feet (1.83 m) or the highest clothes-hanging rod and parallel to the walls at a horizontal distance of 24 inches (600 mm) from the sides and back of the closet walls, respectively, and continuing vertically to the closet ceiling parallel to the walls at a horizontal distance of 12 inches (300 mm) or the width of the shelf, whichever is greater.

For a closet that permits access to both sides of a hanging rod, the storage space shall include the volume below the highest rod extending 12 inches (300 mm) on either side of the rod on a plane horizontal to the floor extending the entire length of the rod.

(B) FIXTURE TYPES PERMITTED *NEC 410.8(B)*

A surface-mounted or recessed incandescent fixture with a completely enclosed lamp.

A surface-mounted or recessed fluorescent fixture.

(C) Fixture Types Not Permitted: *NEC 410.8*

Incandescent fixtures with open or partially enclosed lamps and pendant fixtures or lamp holders shall not be permitted.

(D) Location: *NEC 410.8(D)*

Surface-mounted incandescent fixtures installed on the wall above the door or on the ceiling provided there is a minimum clearance of 12 inches (300 mm) between the fixture and the nearest point of a storage area. *NEC 410.8(D)(1)*

Surface-mounted fluorescent fixtures installed on the wall above the door or on the ceiling provided there is a minimum clearance of 6 inches (150 mm) between the fixture and the nearest point of a storage area. *NEC 410.8(D)(2)*

Recessed incandescent fixtures with a completely enclosed lamp installed in the wall or the ceiling provided there is a minimum clearance of 6 inches (150 mm) between the fixture and the nearest point of a storage area. *NEC 410.8(D)(3)*

Recessed fluorescent fixtures installed in the wall or on the ceiling provided there is a minimum clearance of 6 inches (150 mm) between the fixture and the nearest point of a storage area. *NEC 410.8(D)(4)*

7.3 COVE LIGHTING: Coves shall have adequate space and shall be so located that lamps and equipment can be properly installed and maintained. *NEC 410.9*

7.4 FLUSH AND RECESSED LIGHTING FIXTURES: Recessed portions of lighting fixture enclosures, other than points of support, shall be spaced at least $\frac{1}{4}$ inch (13 mm) from combustible material. Thermal insulation shall not be installed within 3 inches (75 mm) of the recessed fixture enclosure, wiring compartment, or ballast and shall not so be installed above the fixture as to entrap heat and prevent the free circulation of air. *NEC 410.66*

7.5 ADJACENT COMBUSTABLE MATERIAL: Fixtures shall be so installed that adjacent combustible material will not be subjected to temperatures in excess of 90 degrees Celsius (194 degrees Fahrenheit). *NEC 410.65(A)*

8. CONDUCTOR SIZING BASED ON VOLTAGE DROP

8.1 Conductors for branch circuits as defined in Article 100, sized to prevent a voltage drop exceeding 3 percent at the farthest outlet of power, heating and lighting loads, or combinations of such loads, and where the maximum total voltage drop on both feeders and branch circuits to the farthest outlet does not exceed 5 percent, provide reasonable efficiency of operation. See FPN No. 2 of 215.2(A)(3) for voltage drop on feeder conductor. *NEC 210.19(A)(1)(FPN No. 4)*. Also See NFEC Table 16 for conductor sizing based on voltage drop.

9. COOKING APPLIANCE

9.1 INSTALLATION:

9.1.1 A range receptacle should be installed on all free-standing range installations of 12 kW or less.

9.1.2 Flexible cord shall be permitted:

For connection of appliances to facilitate their frequent interchange or to prevent the transmission of noise or vibration.

To facilitate the removal or disconnection of appliances that are fastened in place, where the fastening means and mechanical connections are specifically designed to permit ready removal for maintenance or repair, and the appliance is intended or identified for flexible cord connection. *NEC 422.16(A), (B)(3)*

9.1.3 The frame of the range shall be effectively grounded.

Electric ranges shall be wired with a 4-wire conductor. *NEC 250.138(A) or (B)*

An existing branch-circuit, for an electric range, consisting of a 3-wire conductor may be bonded to the neutral terminal, except in a mobile home. *NEC 250.140*

9.1.4 Range wiring shall be protected with the proper size fuse or breaker per manufacturer's recommendations. *NEC 422.11(A)*

9.1.5 Built-in range components, such as counter-mounted cooking units, surface griddle units, and wall-mounted ovens intended to be mounted separately, may be fed with one feeder in accordance with NEC 210.19. NEC 210.19(A)(3), exceptions 1 and 2

9.1.6 Built-in range components, such as counter-mounted cooking units, surface griddle units, and wall-mounted oven units intended to be mounted separately, may be wired with a separate circuit to each component. NEC 210.19(A)(3), exceptions 1 and 2

10. WATER HEATER WIRING

10.1 INSTALLATION:

10.1.1 For permanently connected appliances rated at not over 300 volt amperes or 1/8 horsepower, the branch-circuit overcurrent device shall be permitted to serve as the disconnected means. *NEC 422.31(A)*

10.1.2 A branch circuit supplying a fixed storage-type water heater having a capacity of 120 gallons (424.2 liters) or less shall have a rating not less than 125 percent of the nameplate rating of the water heater. *NEC 422.13*

10.1.3 Each storage- or instantaneous-type water heater shall be equipped with a temperature-limiting means in addition to its control thermostat to disconnect all ungrounded conductors, and means shall be (1) installed to sense maximum water temperature and (2) either a trip-free, manually reset type or a type having a replacement element. Such water heaters shall be marked to require the installation of a temperature and pressure relief valve. *NEC 422.47*

10.1.4 Grounding: The tank of the water heater shall be grounded by EITHER bonding a bare or insulated ground wire from the non-current carrying frame to the equipment grounding conductor/electrode directly OR along with circuit conductors in the cord and plug cable (fourth wire). *NEC 250.130, 134, 136, 138*

11. CLOTHES DRYER WIRING

11.1 A dryer receptacle shall be installed for all dryer installations.

11.2 Clothes dryer shall be wired with a 4-wire conductor. *NEC 250.138(A)*

11.3 An existing branch-circuit consisting of a 3-wire conductor may be bonded to the neutral terminal, except in mobile homes. *NEC 250.140*

12. FIXED MOTOR-DRIVEN APPLIANCES (WATER PUMP, CENTRAL HEAT PUMP, OR AIR CONDITIONER, FURNACE BLOWER, ETC.)

12.1 All motors over 1/8 hp shall have a means of disconnect location near and in sight of the motor and controller. *NEC 422.32*

12.2 Branch-circuit conductors supplying a single motor shall have an ampacity not less than 125 percent of the full-load current rating. *NEC 430.22(A)*

12.3 DEVICES OTHER THAN FUSES:

12.3.1 Where devices other than fuses are used for motor overload protection, NEC Table 430.37 shall govern the minimum allowable number and location of overload units such as trip coils, relays, or thermal cutouts.

12.3.2 All 3-phase motors are required to be provided with three overload units, one in each phase. The exceptions are those protected by other approved means. Specialty designed or integral-type detectors, with or without supplementary external protective devices, are some exceptions. *NEC 430.38*

13. ELECTRIC SPACE HEAT WIRING

13.1 Electric space heating equipment will not operate safely unless equipment, devices, and circuits are properly sized. The frame of each permanently installed electric heater shall be grounded. *NEC 250.190*

13.2 WIRE SIZING FOR RESISTANCE HEATING: (Derived from conductor tables in NEC 310)

13.2.1 The minimum wire size to electric heating units shall be as follows:

Two-wire No. 12 copper with ground shall be used to units rated 3.5 kW and smaller.

Two-wire No. 10 copper with ground shall be used for units rated 3.6 to 5.5 kW and on all 240-volt portable heater outlets serving equipment rated at not more than 5 kW.

13.3 PORTABLE HEATER RECEPTACLES: Receptacles used on portable heater circuits shall be of at least 20 amps. Three-wire polarized receptacles shall be used and heaters shall be grounded. (Derived by NEC Table 210.24 given the No. 12 copper conductor minimum requirement in 13.2.1 above.)

13.4 DERATING OF CONDUCTORS: *NEC 310.10, Table 310.16*

- 13.4.1 If a branch or feeder circuit supplies a continuous load, the allowable load on the circuit must be derated.
- 13.4.2 A continuous load is a load where the maximum current is expected to continue for 3 hours or more. *NEC 100*
- 13.4.3 Where a branch circuit or feeder circuit supplies a continuous load, the conductor size and overcurrent protection device shall have an ampere rating of not less than 125 percent of the continuous load. *NEC 210.12(A), NEC 210.20(A), NEC 215.2(A), NEC 215.3*
- 13.4.4 The continuous load on the circuit cannot exceed 80 percent of the full load ampere rating of the conductor and overcurrent protection device.

Examples of Derating Conductor Load

Conductor Size	Ampacity/Overcurrent Protection (Amperes)	Maximum Continuous Load (Amperes)
No. 14 copper	15	12
No. 12 copper	20	16
No. 10 copper	30	24
No. 8 copper	40	32
No. 6 copper	55	44

13.5 THERMOSTATS:

- 13.5.1 Each circuit supplying individual room heating units shall have a means of disconnect (other than the main service switch). The branch circuit breaker or fused disconnect, where readily available, may serve as this disconnect. *NEC 424.19*
- 13.5.2 A thermostat can be counted as a disconnecting means under NEC 424.20(A) when the following conditions are met:
 - Provided with a marked "off" position,
 - Directly opens all ungrounded conductors when manually placed in the "off" position,
 - Designed so that the circuit cannot be energized automatically after the device has been manually placed in the "off" position, and located as specified in *NEC 424.19*.

14. CENTRAL SPACE HEATING AND AIR CONDITIONING

- 14.1 **GENERAL:** The following are specifications for centrally installed electric heating and air conditioning equipment, heat pumps, furnaces, duct or plenum heaters, air conditioner compressors, etc.
- 14.2 **LOCATION AND CLEARANCE:** Air handling units and heating equipment should be installed within the heated space whenever possible. Filters, belts, blower equipment, electronic cleaning equipment, and humidifiers should be readily accessible for service and maintenance by the user. In no case shall equipment be installed without adequate clearance for service and replacement of the equipment. Heaters and related equipment installed in damp or wet locations shall be approved for such locations and shall be constructed and installed so that water or other liquids cannot enter or accumulate in or on wire sections, electrical components, or ductwork. *NEC 424.12(B)*
- 14.3 **DISCONNECTING MEANS:**
 - 14.3.1 Means shall be provided to disconnect the heater, motor controller(s), and supplementary overcurrent protective device(s) of all fixed electric space-heating equipment from all ungrounded conductors. Where heating equipment is supplied by more than one source, the disconnecting means shall be grouped and marked. *NEC 424.19*
 - 14.3.2 **Heating Equipment with Supplementary Overcurrent Protection:** The disconnecting means for fixed electric space-heating equipment with supplementary overcurrent protection shall be within sight from the supplementary overcurrent protective device(s), on the supply side of these devices, if fuses, and in addition, shall comply with either NEC 424.19(A)(1) or (2).
- 14.4 **OVERCURRENT PROTECTION:**
 - 14.4.1 **Resistance Elements:** Resistance-type heating elements in electric space heating equipment shall be protected at not more than 60 amperes. Equipment rated more than 48 amperes and employing such elements shall have the heating elements subdivided, and each subdivided load shall not exceed 48 amperes. Where a subdivided load is less than 48 amperes the rating of the supplementary overcurrent protective device shall comply with 424.3(B). A boiler employing resistance-type immersion heating elements contained in an ASME rated and stamped vessel shall be permitted to comply with 424.72(A). *NEC 424.22(B)*
 - 14.4.2 Overcurrent protective devices shall be factory-installed within or on the heater enclosure or supplied for use with the heater as a separate assembly by the heater manufacturer, be accessible but need not be readily accessible, and be suitable for branch-circuit protection. Where cartridge fuses are used to provide this

overcurrent protection, a single disconnecting means shall be permitted to be used for the several subdivided loads.
NEC 424.22(C)

14.4.3 The main conductors supplying these overcurrent protective devices shall be considered branch-circuit conductors. *NEC 424.22(D)*

14.5 **CIRCUIT CAPACITY:**

14.5.1 440.6 Ampacity and Rating: The size of conductors for equipment covered by this article shall be selected from Tables 310.16 through 310.19 or calculated in accordance with 310.15 as applicable. The required ampacity of conductors and rating of equipment shall be determined according to NEC 440.6(A) and NEC 440.6(B).

14.6 **LOW VOLTAGE CONTROL WIRING:**

14.6.1 Sizes and Use: Conductors of sizes 18 AWG and 16 AWG shall be permitted to be used, provided they supply loads that do not exceed the ampacities given in 402.5 and are installed in a raceway, an approved enclosure, or a listed cable. Conductors larger than 16 AWG shall not supply loads greater than the ampacities given in 310.15. Flexible cords shall comply with Article 400.

14.6.2 Insulation: Insulation on conductors shall be suitable for 600 volts. Conductors larger than 16 AWG shall comply with Article 310. Conductors in sizes 18 AWG and 16 AWG shall be Type FFH-2, KF-2, HFF-2, PAF, PAFF, PF, PFF, PGF, PGFF, PTF, PTFF, RFH-2, RFHH-2, RFHH-3, SF-2, SFF-2, TF, TFF, TFFN, TFN, ZF, or ZFF. Conductors with other types and thicknesses of insulation shall be permitted if listed for Class 1 circuit use. *NEC 725.27(B)*

15. AGRICULTURAL BUILDING (NEC 547)

15.1 **SCOPE:** *NEC 547.1*

15.1.1 The provisions of this article shall apply to the following agricultural buildings or that part of a building or adjacent areas of similar or like nature as specified in 547.1(A) and (B).

Excessive Dust and Dust with Water. Agricultural buildings where excessive dust and dust with water may accumulate, including all areas of poultry, livestock, and fish confinement systems, where litter dust or feed dust, including mineral feed particles, may accumulate.

Corrosive Atmosphere. Agricultural buildings where a corrosive atmosphere exists. Such buildings include areas where the following conditions exist:

Poultry and animal excrement may cause corrosive vapors.

Corrosive particles may combine with water.

The area is damp and wet by reason of periodic washing for cleaning and sanitizing with water and cleansing agents.

Similar conditions exist.

15.2 **DEFINITIONS:** *NEC 547.2*

15.2.1 **Distribution Point:** An electrical supply point from which service drops, service laterals, feeders, or branch circuits to agricultural buildings, associated farm dwelling(s), and associated buildings under single management are supplied.

FPN No. 1: Distribution points are also known as the center yard pole, meter pole or the common distribution point.

FPN No. 2: The service point as defined in Article 100 is typically at the distribution point.

15.2.2 **Equipotential Plane:** An area where wire mesh or other conductive elements are embedded in or placed under concrete, bonded to all metal structures and fixed nonelectrical equipment that may become energized, and connected to the electrical grounding system to prevent a difference in voltage from developing within the plane.

15.3 **OTHER ARTICLES:** *NEC 547.3*

15.3.1 For agricultural buildings not having conditions as specified in 547.1, the electrical installations shall be made in accordance with the applicable articles in this Code.

15.4 **SURFACE TEMPERATURES:** *NEC 547.4*

15.4.1 Electrical equipment or devices installed in accordance with the provisions of this article shall be installed in a manner such that they will function at full rating without developing surface temperatures in excess of the specified normal safe operating range of the equipment or device.

15.5 **WIRING METHODS:** *NEC 547.5*

15.5.1 **Wiring Systems:** Types UF, NMC, copper SE cables, jacketed Type MC cable, rigid nonmetallic conduit, liquid-tight flexible nonmetallic conduit, or other cables or raceways suitable for the location, with approved termination fittings, shall be the wiring methods employed. Article 502 wiring methods shall be permitted for areas described in 547.1(A).

FPN: See 300.7 and 352.44 for installation of raceway systems exposed to widely different temperatures.

15.5.2 **Mounting:** All cables shall be secured within 200 mm (8 in.) of each cabinet, box, or fitting. The 6-mm (14-in.) airspace required for nonmetallic boxes, fittings, conduit, and cables in 300.6(C) shall not be required in buildings covered by this article.

15.5.3 Equipment Enclosures, Boxes, Conduit Bodies, and Fittings:

Excessive Dust. Equipment enclosures, boxes, conduit bodies, and fittings installed in areas of buildings where excessive dust may be present shall be designed to minimize the entrance of dust and shall have no openings (such as holes for attachment screws) through which dust could enter the enclosure.

Damp or Wet Locations. In damp or wet locations, equipment enclosures, boxes, conduit bodies, and fittings shall be placed or equipped so as to prevent moisture from entering or accumulating within the enclosure, box, conduit body, or fitting. In wet locations, including normally dry or damp locations where surfaces are periodically washed or sprayed with water, boxes, conduit bodies, and fittings shall be listed for use in wet locations and equipment enclosures shall be weatherproof.

15.5.4 Corrosive Atmosphere: Where wet dust, excessive moisture, corrosive gases or vapors, or other corrosive conditions may be present, equipment enclosures, boxes, conduit bodies, and fittings shall have corrosion resistance properties suitable for the conditions.

FPN No. 1: See Table 430.91 for appropriate enclosure type designations.

FPN No. 2: Aluminum and magnetic ferrous materials may corrode in agricultural environments.

15.5.5 Flexible Connections: Where necessary to employ flexible connections, dust-tight flexible connectors, liquid-tight flexible conduit, or flexible cord listed and identified for hard usage shall be used. All connectors and fittings used shall be listed and identified for the purpose.

15.5.6 Physical Protection: All electrical wiring and equipment subject to physical damage shall be protected.

15.5.7 Separate Equipment Grounding Conductor: Non-current-carrying metal parts of equipment, raceways, and other enclosures, where required to be grounded, shall be grounded by a copper equipment grounding conductor installed between the equipment and the building disconnecting means. If installed underground, the equipment grounding conductor shall be insulated or covered.

15.5.8 Receptacles: All 125-volt, single-phase, 15- and 20-ampere general-purpose receptacles installed in the following locations shall have ground-fault circuit-interrupter protection for personnel:

1. In areas having an equipotential plane.
2. Outdoors.
3. In damp or wet locations.
4. In dirt confinement areas for livestock.

15.6 SWITCHES, RECEPTACLES, CIRCUIT BREAKERS, CONTROLLERS, AND FUSES: (NEC 547.6)

15.6.1 Switches, including pushbuttons, relays, and similar devices, receptacles, circuit breakers, controllers, and fuses, shall be provided with enclosures as specified in NEC 547.5(C).

15.7 MOTORS: *NEC 547.7*

15.7.1 Motors and other rotating electrical machinery shall be totally enclosed or designed so as to minimize the entrance of dust, moisture, or corrosive particles.

15.8 LUMINAIRES (LIGHTING FIXTURES): *NEC 547.8*

15.8.1 Luminaires (lighting fixtures) shall comply with the following:

Minimize the Entrance of Dust. Luminaires shall be installed to minimize the entrance of dust, foreign matter, moisture, and corrosive material.

Exposed to Physical Damage. Any luminaire that may be exposed to physical damage shall be protected by a suitable guard.

Exposed to Water. A luminaire that may be exposed to water from condensation, building cleansing water, or solution shall be watertight.

15.9 ELECTRICAL SUPPLY TO BUILDING OR STRUCTURES FROM A DISTRIBUTION POINT: *NEC 547.9*

15.9.1 Site-Isolating Device where Required: A disconnecting means shall be installed at the distribution point where two or more agricultural buildings, structures, associated farm dwelling(s), or other buildings are supplied from the distribution point.

Location: The site-isolating device shall be pole-mounted and shall meet the clearance requirements of NEC Article 230.24(A).

Operation: The site isolating devices shall simultaneously interrupt all ungrounded conductors from the premises wiring.

Bonding Provisions: The site-isolating device enclosure shall be bonded to the grounded circuit conductor and the grounding electrode system.

Grounding: At the site-isolating device, the system grounded conductor shall be connected to a grounding electrode system via a grounding electrode conductor.

Rating. The disconnecting means shall be rated for the calculated load as determined by Part IV of Article 220.

Overcurrent Protection. The site-isolating device shall not be required to provide overcurrent protection.

Accessibility. Where the site-isolating device is not readily accessible, it shall be capable of being remotely operated by an operating handle installed at a readily accessible location. Not readily accessible, the disconnecting means shall be capable of operation from a readily accessible point.

Series Devices: an additional site-isolating device for premises wiring shall not be required where a site-isolating device meeting all applicable requirements of this section is provided by the serving utility as part of their service requirements.

15.9.2 Service Disconnecting Means and Overcurrent Protection at the Building(s) or Structure(s). Where the disconnecting means and overcurrent protection are located at the buildings or structures, the requirements of NEC 547.9(B) (1) through (B) (3) shall apply.

(a) The grounded circuit conductor shall be permitted to be connected to the building disconnecting means and to the grounding electrode system of that building or structure where all the requirements of 250.32(B) (2) are met.

(b) A separate equipment grounding conductor shall be run with the supply conductors to the building(s) or structure(s) and the following conditions shall be met:

(1) The equipment grounding conductor shall be the same size as the largest supply conductor, if of the same material, or is adjusted in size in accordance with the equivalent size columns of Table 250.122 if of different material.

(2) The equipment grounding conductor is bonded to the grounded circuit conductor and the site-isolating device at the distribution point.

(3) A grounding electrode system is provided in accordance with Part III of Article 250 and connected to the equipment grounding conductor at the building(s) or structure(s) disconnecting means.

(4) The grounded circuit conductor is not connected to a grounding electrode or to any equipment grounding conductor on the load side of the distribution point.

Disconnecting Means and Overcurrent Protection at the Distribution Point. Where the disconnecting means and overcurrent protection for each set of feeder conductors are located at the distribution point, feeders to building(s) or structure(s) shall meet the requirements of 250.32 and Article 225, Parts I and II.

FPN: Methods to reduce neutral-to-earth voltages in livestock facilities include supplying buildings or structures with 4-wire, single-phase services, sizing of 3-wire service conductors to limit voltage drop to 2 percent, and connecting loads line-to-line.

Direct buried equipment grounding conductors: where livestock is housed, any portion of a direct-buried equipment grounding conductor or run to the building or structure shall be insulated or covered copper.

15.9.3 Equipotential Planes and Bonding of Equipotential Planes.

(a) Where required: Equipotential planes shall be installed in all concrete floor confinement areas in livestock buildings, and in all outdoor confinement areas such as feed lots, containing metallic equipment that may become energized and is accessible to livestock. The equipotential plane shall encompass the area where the livestock stands while accessing metallic equipment that may become energized.

(b) Bonding: Equipotential planes shall be bonded to the electrical grounding system. The bonding conductor shall be copper, insulated, covered or bare, and not smaller than 8 AWG. The means of bonding to wire mesh or conductive elements shall be by pressure connectors or clamps of brass, copper, copper alloy, or an equally substantial approved means. Slatted floors that are supported by structures that are a part of an equipotential plane shall not require bonding.

16. MOBILE HOMES (NEC 550)

16.1 DEFINITIONS:

16.1.1 Mobile Home: A factory-assembled structure or structures transportable in one or more sections that is built on a permanent chassis and designed to be used as a dwelling without a permanent foundation where connected to the required utilities and that includes the plumbing, heating, air conditioning, and electric systems contained therein. For the purpose of this Code and unless otherwise indicated, the term mobile home includes manufactured homes. *NEC 550.2*

16.1.2 Mobile Home Service Equipment: The equipment containing the disconnecting means, overcurrent protective devices, and receptacles or other means for connecting a mobile home feeder assembly. *NEC 550.2*

16.1.3 In Other Than Mobile Home Parks: Mobile homes installed in other than mobile home parks shall comply with the provisions of this article. *NEC 550.4(B)*

16.2 MOBILE HOME SERVICES:

16.2.1 Mobile Home Service Equipment: The mobile home service equipment shall be located adjacent to the mobile home and not mounted in or on the mobile home. The service equipment shall be located in sight from and not more than 9.0 m (30 ft) from the

exterior wall of the mobile home it serves. The service equipment shall be permitted to be located elsewhere on the premises, provided that a disconnecting means suitable for service equipment is located in sight from and not more than 9.0 m (30 ft) from the exterior wall of the mobile home it serves and is not rated less than 100 amps at 120/240 volts. Grounding at the disconnecting means shall be in accordance with 250.32. *NEC 550.32(A) and 550.32.(C)*

16.2.2 Rating: Mobile home service equipment shall be rated at not less than 100 amperes at 120/240 volts, and provisions shall be made for connecting a mobile home feeder assembly by a permanent wiring method. Power outlets used as mobile home service equipment shall also be permitted to contain receptacles rated up to 50 amperes with appropriate overcurrent protection. Fifty-ampere receptacles shall conform to the configuration shown in Figure 550.10(C). *NEC 550.32(C)*

16.2.3 Definition: Arc-fault circuit interrupters are defined in 210.12(A). *NEC 550.25(A)*

44 16.2.4 Bedrooms of Mobile Homes and Manufactured Homes: All branch circuits that supply 125-volt, single-phase, 15- and 20-ampere outlets installed in bedrooms of mobile homes and manufactured homes shall be protected by arc-fault circuit interrupter(s). *NEC 550.25(B)*

16.2.5 Mast Weatherhead or Raceway: Where the calculated load exceeds 50 amperes or where a permanent feeder is used, the supply shall be by means of:

One mast weatherhead installation installed in accordance with Article NEC 230 containing 4 continuous, insulated, color-coded, feeder conductors, one of which shall be an equipment grounding conductor.

A metal raceway or rigid nonmetallic conduit from the disconnecting means in the mobile home to the underside of the mobile home, with provisions for the attachment to a suitable junction box or fitting to the raceway on the underside of the mobile home with or without conductors as in 550.10 (I)(1). The manufacturer shall provide written installation instructions stating the proper feeder conductor sizes for the raceway and the size of the junction box to be used. *NEC 550.10(I)(2)*

16.3 GROUNDING: Grounding of both electrical and nonelectrical metal parts in a mobile home shall be through connection to a grounding bus in the mobile home distribution panelboard. The grounding bus shall be grounded through the green-colored insulated conductor in the supply cord or feeder wiring to the service ground in the service-entrance equipment located adjacent to the mobile home location. Neither the frame of the mobile home nor the frame of any appliance shall be connected to the grounded

circuit conductor (neutral) in the mobile home. Where the distribution panel is the service equipment as permitted by NEC 550.32(B), the neutral conductors and equipment grounding bus shall be connected. *NEC 550.16*

16.3.1 Insulated Neutral:

Insulated. The grounded circuit conductor (neutral) shall be insulated from the grounding conductors and from equipment enclosures and other grounded parts. The grounded (neutral) circuit terminals in the distribution panel board and in ranges, clothes dryers, counter-mounted cooking units, and wall-mounted ovens shall be insulated from the equipment enclosure.

Bonding screws, straps, or buses in the distribution panel board or in appliances shall be removed and discarded. Where the distribution panelboard is the service equipment as permitted by 550.32(B), the neutral conductors and the equipment bonding bus shall be connected. *NEC 550.16(A)(1)*

Connections of Ranges and Clothes Dryers. Connections of ranges and clothes dryers with 120/240-volt, 3-wire ratings shall be made with a 4-conductor cord and 3-pole, 4-wire, grounding-type plugs or by Type AC cable, Type MC cable, or conductors enclosed in flexible metal conduit. *NEC 550.16(A)(2)*

16.3.2 Equipment Grounding Means:

Supply cord or Permanent Feeder. The green-colored insulated grounding wire in the supply cord or permanent feeder wiring shall be connected to the grounding bus in the distribution panelboard or disconnecting means. *NEC 550.16(B)(1)*

Electrical System. In the electrical system, all exposed metal parts, enclosures, frames, lamp fixture canopies, etc., shall be effectively bonded to the grounding terminal or enclosure of the distribution panelboard. *NEC 550.16(B)(2)*

Cord-Connected Appliances. Cord-connected appliances, such as washing machines, clothes dryers, refrigerators, and the electrical system of gas ranges, etc., shall be grounded by means of a cord with grounding conductor and grounding-type attachment plug. *NEC 550.16(B)(3)*

16.3.3 Bonding of Non-Current-Carrying Metal Parts:

Exposed Non-Current-Carrying Metal Parts. All exposed non-current-carrying metal parts that may become energized shall be effectively bonded to the grounding terminal or enclosure of the distribution panelboard. A bonding conductor shall be connected between the distribution panelboard and accessible terminal on the chassis. *NEC 550.16(C)(1)*

Grounding Terminals. Grounding terminals shall be of the solderless type and listed as pressure-terminal connectors recognized for the wire size used. The bonding conductor shall be solid or stranded, insulated or bare, and shall be No. 8 copper minimum, or equal. The bonding conductor shall be routed so as not to be exposed to physical damage. *NEC 550.16(C)(2)*

Metallic Piping And Ducts. Metallic gas, water, and waste pipes and metallic air-circulating ducts shall be considered bonded if they are connected to the terminal on the chassis by clamps, solderless connectors, or by suitable grounding-type straps. *NEC 550.16(C)(3)*

Metallic Roof and Exterior Covering. Any metallic roof and exterior covering shall be considered bonded if

(a) the metal panels overlap one another and are securely attached to the wood or metal frame parts by metallic fasteners, and

(b) the lower panel of the metallic exterior covering is secured by metallic fasteners at a cross member of the chassis by two metal straps per mobile home unit or section at opposite ends. *NEC 550.16(C)(4)*

The bonding strap material shall be a minimum of 4 inches (100 mm) in width of material equivalent to the skin or a material of equal or better electrical conductivity. The straps shall be fastened with paint-penetrating fittings, such as screws and starwashers or equivalent. *NEC 550.16(C)(4)*

Feeder Conductors. Feeder conductors shall consist of either a listed cord, factory installed in accordance with 550.10 (B), or a permanently installed feeder consisting of 4, insulated, color-coded conductors that shall be identified by the factory or field marking of the conductors in compliance with 310.12. Equipment grounding conductors shall not be identified by stripping the insulation. *NEC 550.33(A)*

17. OUTSIDE WIRING

17.1 CONDUCTOR SIZE AND SUPPORT:

17.1.1 Overhead Spans: Overhead individual conductors shall not be smaller than the following: For 600 volts, nominal or less, No. 10 copper or No. 8 aluminum for spans up to 50 feet (15 m) in length and No. 8 copper or No. 6 aluminum for a longer span. *NEC 225.6(A)(1)*

17.1.2 All outbuildings shall have a means provided for disconnecting all ungrounded conductors that supply or pass through the building or structure. *NEC 255.31*

17.1.3 All outside wiring on member premises shall give proper clearance over driveways, roadways, walks, etc. See 3.2(1) - 3.2(4). *NEC 225.18*

17.1.4 Mechanical Protection of Conductors: Mechanical protection of conductors on buildings, structures or poles shall be provided for services in NEC 230.50. *NEC 225.20*

17.1.5 Vegetation as Support: Vegetation such as trees shall not be used for support of overhead conductor spans. *NEC 225.26*

18. UNDERGROUND FEEDER AND BRANCH CIRCUIT CABLE (Does Not Refer to Service Entrances)

18.1 UNDERGROUND FEEDER (UF):

18.1.1 Underground feeder and branch-circuit cable shall be an approved Type UF cable in sizes No. 14 copper or No. 12 aluminum or copper-clad aluminum through No. 4/0 (*NEC 340.104*). The conductors of Type UF shall be one of the moisture-resistant types listed in NEC Table 310-13, that is suitable for branch-circuit wiring, or one which is identified for such use where installed as a substitute for NM cable, the the conductor insulation shall be rated 90°C (194°F)(*NEC 340.112*). In addition to the insulated conductors, the cable shall be permitted to have an approved size of insulated or bare conductor for equipment grounding purposes only (*NEC 340.108*). The overall covering shall be flame-retardant, moisture, fungus and corrosion-resistant, and suitable for direct burial in the earth (*NEC 340.116*).

18.1.2 Type UF cable shall be durably marked on the surface. The AWG size or circular mil area shall be repeated at intervals not exceeding 24 inches (610 mm). All other markings shall be repeated at intervals not exceeding 40 inches (1.0 m). *NEC 310.11(B)(1)*

18.1.3 A minimum depth of 24 inches (610 mm) shall be maintained for conductors and cables buried directly in the earth. The depth may be reduced to 18 inches (457 mm), provided supplemental protective covering such as a 2-inch (50.8 mm) concrete pad or non-metallic raceway is used. *NEC Table 300.5*

18.1.4 Type UF cable is defined as a listed factory assembly of one or more insulated conductors with an integral or overall covering of nonmetallic material suitable for direct burial in the earth. *NEC 340.2*

18.1.5 Type UF cable shall be permitted as follows:

For use underground, including direct burial in the earth.

As single-conductor cables. When installed as single-conductor cables, all conductors of the feeder grounded conductor or branch circuit, including the grounded conductor and equipment grounding conductor, if any, shall be installed in accordance with NEC 300.3.

For wiring in wet, dry, or corrosive locations under the recognized wiring methods of this Code.

Installed as nonmetallic-sheathed cable. Where so installed, the installation and conductor requirements shall comply with the provisions of NEC Article 334 and shall be of the multi-conductor type.

For photovoltaic systems in accordance with NEC 690.31.

As single-conductor cables as the non-heating leads for heating cables as provided in NEC 424.43.

Supported by cable trays. Type UF cable supported by cable trays shall be of the multi-conductor type. *NEC 340.10*

18.1.6 Type UF cable shall not be used as follows: (1) As service-entrance cables. (2) In commercial garages. (3) In theaters. (4) In motion picture studios. (5) In storage battery rooms. (6) In hoistways, or on elevators or escalators. (7) In hazardous (classified) locations. (8) Embedded in poured cement, concrete, or aggregate, except where embedded in plaster as non-heating leads where permitted in 424.43. (9) Where exposed to direct rays of the sun, unless identified as sunlight-resistant. (10) Where subject to physical damage. (11) As overhead cable, except where installed as messenger-supported wiring in accordance with NEC Article 396 Part II. *NEC 340.12*

TABLES

Table 310.16 Allowable Ampacities of Insulated Conductors Rated 0 Through 2000 Volts, 60°C Through 90°C (140°F Through 194°F), Not More Than Three Current-Carrying Conductors in Raceway, Cable, or Earth (Directly Buried), Based on Ambient Temperature of 30°C (86°F)

Size AWG or kcmil	Temperature Rating of Conductor (See Table 310.13.)						Size AWG or kcmil
	60°C (140°F)	75°C (167°F)	90°C (194°F)	60°C (140°F)	75°C (167°F)	90°C (194°F)	
	Types TW, UF	Types RHW, THHW, THW, THWN, XHHW, USE, ZW	Types TBS, SA, SIS, FEP, FEPB, MI, RHH, RHW-2, THHN, THHW, THW-2, USE-2, XHH, XHHW, XHHW-2, ZW-2	Types TW, UF	Types RHW, THHW, THW, THWN, XHHW, USE	Types TBS, SA, SIS, THHN, THHW, THW-2, THWN-2, RHH, RHW-2, USE-2, XHH, XHHW, XHHW-2, ZW-2	
	COPPER			ALUMINUM OR COPPER-CLAD ALUMINUM			
18	—	—	14	—	—	—	—
16	—	—	18	—	—	—	—
14*	20	20	25	—	—	—	—
12*	25	25	30	20	20	25	12*
10*	30	35	40	25	30	35	10*
8	40	50	55	30	40	45	8
6	55	65	75	40	50	60	6
4	70	85	95	55	65	75	4
3	85	100	110	65	75	85	3
2	95	115	130	75	90	100	2
1	110	130	150	85	100	115	1
1/0	125	150	170	100	120	135	1/0
2/0	145	175	195	115	135	150	2/0
3/0	165	200	225	130	155	175	3/0
4/0	195	230	260	150	180	205	4/0
250	215	255	290	170	205	230	250
300	240	285	320	190	230	255	300
350	260	310	350	210	250	280	350
400	280	335	380	225	270	305	400
500	320	380	430	260	310	350	500
600	355	420	475	285	340	385	600
700	385	460	520	310	375	420	700
750	400	475	535	320	385	435	750
800	410	490	555	330	395	450	800
900	435	520	585	355	425	480	900
1000	455	545	615	375	445	500	1000
1250	495	590	665	405	485	545	1250
1500	520	625	705	435	520	585	1500
1750	545	650	745	455	545	615	1750
2000	560	665	750	470	560	630	2000

CORRECTION FACTORS

Ambient Temp. (°C)	For ambient temperatures other than 30°C (86°F), multiply the allowable ampacities shown above by the appropriate factor shown below.						Ambient Temp. (°F)
21-25	1.08	1.05	1.04	1.08	1.05	1.04	70-77
26-30	1.00	1.00	1.00	1.00	1.00	1.00	78-86
31-35	0.91	0.94	0.96	0.91	0.94	0.96	87-95
36-40	0.82	0.88	0.91	0.82	0.88	0.91	96-104
41-45	0.71	0.82	0.87	0.71	0.82	0.87	105-113
46-50	0.58	0.75	0.82	0.58	0.75	0.82	114-122
51-55	0.41	0.67	0.76	0.41	0.67	0.76	123-131
56-60	—	0.58	0.71	—	0.58	0.71	132-140
61-70	—	0.33	0.58	—	0.33	0.58	141-158
71-80	—	—	0.41	—	—	0.41	159-176

* See 240.4(D).

FOOTNOTE FOR TABLE 310.16. Unless specifically permitted in NEC 240.4(E) through (G), the overcurrent protection shall not exceed 15 amperes for 14 AWG, 20 amperes for 12 AWG, and 30 amperes for 10 AWG copper; or 15 amperes for 12 AWG and 25 amperes for 10 AWG aluminum and copper-clad aluminum after any correction factors for ambient temperature and number of conductors have been applied. *NEC 240.4(D)*

**EMC Diagram 2
DOUBLE-THROW SWITCH INSTALLATION**

The stand-by generator shall be provided with transfer equipment for shifting from one source to another. This double-throw switch shall prevent the inadvertent inter-connection of normal and alternate sources of supply. *NEC 702.6*

The transfer equipment shall be permitted to contain supplementary overcurrent protection having an interruptible rating sufficient for the available fault current that the generator can deliver. *NEC 702.6*

The stand-by generator shall be grounded in accordance with *NEC 250.30*.

Rule-of-thumb sizing method for stand-by generator:
2-hp per kW of load.

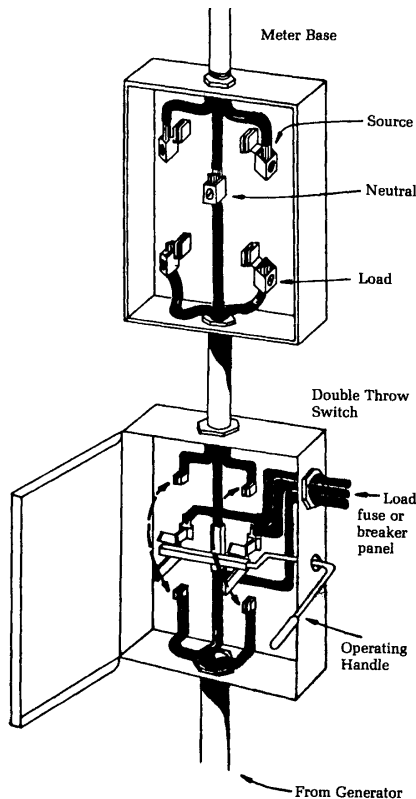
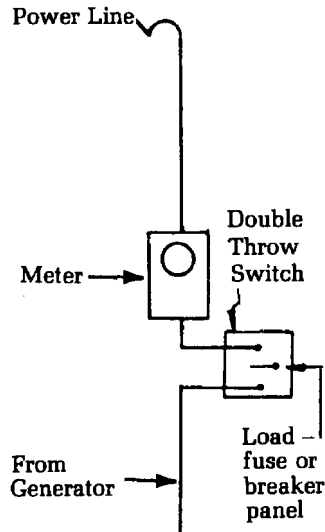

RESIDENTIAL WIRING CALCULATIONS (see NEC ANNEX D)

Example D1(a). One-Family Dwelling

The dwelling has a floor area of 1500 sq. ft. exclusive of an unfinished cellar not adaptable for future use, unfinished attic, and open porches. Appliances are a 12-kW range and a 5.5 kW, 240-V dryer. Assume range and dryer kW ratings equivalent to kVA ratings in accordance with 220.18 and 220.19.

Computed Load [see 220.10]

General Lighting Load:
1500 sq. ft. at 3 VA per sq. ft. = 4500 VA

Minimum Number of Branch Circuits Required (see 210.11[A])

- General Lighting Load:
4500 VA ÷ 120 V = 37.5 A: This requires three 15-A, 2-wire or two 20-A, 2-wire circuits.
- Small Appliance Load: Two 2-wire, 20-A circuits [see 210.11(C)(1)]
- Laundry Load: One 2-wire, 20-A circuit [see 210.11(C)(2)]
- Bathroom Branch Circuit: One 2-wire, 20-A circuit (no additional load calculation is required for this circuit) [see 210.11(C)(3)]

Minimum Size Feeder Required (see 220.10)

General Lighting	4500 VA
Small Appliance Load	3000 VA
Laundry	<u>1500 VA</u>
Total	9000 VA
3000 VA at 100%	3000 VA
9000 VA - 3000 VA = 6000 VA at 35%	<u>2100 VA</u>
Net Load	5100 VA
Range (see Table 220.55)	8000 VA
Dryer Load (see Table 220.54)	<u>5500 VA</u>
Net Computed Load	18,600 VA

Net Computed Load for 120 / 240-V, 3-wire, single-phase service or feeder:

$18,600 \text{ VA} \div 240 \text{ V} = 77.5 \text{ A}$

Sections 230.42(B) and 230.79 require service conductors and disconnecting means rated not less than 100 A.

Calculation for Neutral for Feeder and Service

Lighting and Small Appliance Load	5100 VA
Range: 8000 VA at 70% (see 220.61)	5600 VA
Dryer 5500 VA at 70% (see 220.61)	<u>3850 VA</u>
Total	14,550 VA

Computed Load for Neutral:
 $14,550 \text{ VA} \div 240 \text{ V} = 60.6 \text{ A}$

Example D1(b). One-Family Dwelling

Assume same conditions as Example No. D1(a), plus addition of one 6-A, 230-V, room air-conditioning unit and one 12-A, 115-V, room air-conditioning unit*, one 8-A, 115-V, rated waste disposer, and one 10-A, 120-V, rated dishwasher. See Article 430 for general motors and Article 440, Part VII, for air-conditioning equipment. Motors have nameplate ratings of 115 V and 230 V for use on 120-V and 240-V nominal voltage systems.

*(For feeder neutral, use larger of the two appliances for unbalance.)

From Example D1(a), feeder current is 78 A (3-wire 240 V).

	Line A	Neutral	Line B
Amperes from Example D1(a)	78	61	78
One 230-V air conditioner	6	—	6
One 115-V air conditioner and 120-V dishwasher	12	12	10
One 115-V disposer	—	8	8
25% of largest motor (see 430.24)	3	3	2
Total amperes per line	99	84	104

Therefore, the service would be rated 110 A.

Example D2(a). Optional Calculation for One-Family Dwelling, Heating Larger than Air Conditioning (see 220.82)

The dwelling has a floor area of 1500 sq. ft., exclusive of an unfinished cellar not adaptable for future use, unfinished attic, and open porches. It has a 12-kW range, a 2.5-kW water heater, a 1.2-kW dishwasher, 9 kW of electric space heating installed in five rooms, a 5-kW clothes dryer, and a 6-A 230-V room air-conditioning unit. Assume range, water heater, dishwasher, space heating, and clothes dryer kW ratings equivalent to kVA.

Air Conditioner kVA Calculation
 $6A \times 230V \div 1000 = 1.38 \text{ kVA}$

This 1.38 kVA [item 1 from 220.82(C)] is less than 40% of 9 kVA of separately controlled electric heat [item 6 from 220.82(C)], so the 1.38 kVA need not be included in the service calculation.

General Load

1500 sq. ft. at 3 VA 4500 VA
 Two 20-A appliance outlet circuits (1500 VA ea) 3000 VA
 Laundry circuit 1500 VA
 Range (at nameplate rating) 12,000 VA
 Water heater 2500 VA
 Dishwasher 1200 VA
 Clothes dryer 5000 VA
 Total 29,700 VA

Application of Demand Factor (see 220.30[B])

First 10 kVA of general load at 100% 10,000 VA
 Remainder of general load at 40%
 (19.7 kVA x 0.4) 7880 VA
 Total of general load 17,880 VA
 9 kVA of heat at 40% (9000 VA x 0.4) = 3600 VA
 Total 21,480 VA

Calculated Load for Service Size:

$21.48 \text{ kVA} = 21,480 \text{ VA}$
 $21,480 \text{ VA} \div 240 \text{ V} = 89.5 \text{ A}$

Therefore, the minimum service rating would be 100 A in accordance with 230.42 and 230.79.

Feeder Neutral Load, per 220.22

1500 sq. ft. at 3 VA 4500 VA
 Three 20-amp. circuits at 1500 VA 4500 VA
 Total 9000 VA
 3000 VA at 100% 3000 VA
 9000 VA - 3000 VA = 6000 V-As at 35% 2100 VA
 Subtotal 5100 VA
 Range: 8 kVA at 70% 5600 VA
 Clothes dryer: 5 kVA at 70% 3500 VA
 Dishwasher 1200 VA
 Total 15,400 VA

Calculated load for neutral
 $15,400 \text{ VA} \div 240 \text{ V} = 64.2 \text{ A}$

Example No. D2(b). Optional Calculation for One-Family Dwelling, Air Conditioning Larger than Heating

The dwelling has a floor area of 1500 sq. ft. exclusive of unfinished cellar not adaptable for use, unfinished attic, and open porches. It has two 20-A small appliance circuits, one 20-A laundry circuit, two 4-kW wall-mounted ovens, one 5.1-kW counter-mounted cooking unit, a 4.5-kW water heater, a 1.2-kW dishwasher, a 5-kW combination clothes washer and dryer, six 7-A 230-V room air-conditioning units, and a 1.5-kW permanently installed bathroom space heater. Assume wall-mounted ovens, counter-mounted cooking unit, water heater, dishwasher, and combination clothes washer and dryer kW ratings equivalent to kVA.

Air Conditioning kVA Calculation:
 Total Amperes 6 units x 7A = 42 A
 $42 \text{ A} \times 240 \text{ V} \div 1000 = 10.08 \text{ kVA}$ (assume P.F. = 1.0)

Load included at 100%:
 Air conditioning: Included below (see item 1 in 220.82[C])
 Space heater: Omit (see item 5 in 220.82 [C])

General Load:

1500 sq. ft. at 3 VA	4500 VA
Two 20-amp. small appliance circuits at 1500 VA	3000 VA
Laundry circuit	1500 VA
Two ovens	8000 VA
One cooking unit	5100 VA
Water heater	4500 VA
Dishwasher	1200 VA
Washer/dryer	5000 VA
Total general load	32,800 VA
First 10 kVA at 100%	10,000 VA
Remainder at 40% (22.8 kVA x 0.4 x 1000)	9120 VA
Subtotal general load	19,120 VA
Air conditioning	10,080 VA
Total	29,200 VA

$29,200 \text{ VA} \div 240 \text{ V} = 122 \text{ A}$ (service rating)

Feeder Neutral Load, per 220.61

54 Assumed that the two 4 kVA wall-mounted ovens are supplied by one branch circuit, the 5.1 kVA counter-mounted cooking unit by a separate circuit.

1500 sq. ft. at 3 VA	4500 VA
Three 20-amp. circuits at 1500 VA	4500 VA
Subtotal	9000 VA
3000 VA at 100%	3000 VA
9000 VA - 3000 VA = 6000 VA at 35%	2100 VA
Subtotal	5100 VA

Two 4 kVA ovens plus one 5.1 kVA cooking unit totals 13.1 kVA.
Table 220-19 permits 55% demand factor or
 $13.1 \text{ kVA} \times 0.55 = 7.2 \text{ kVA}$ feeder capacity

Subtotal from above	5100 VA
Ovens and cooking unit:	
7200 VA X 70% for neutral load	5040 VA
Clothes washer/dryer:	
5 kVA X 70% for neutral load	3500 VA
Dishwasher	1200 VA
Total	14,840 VA

Calculated load for neutral
 $14,840 \text{ VA} \div 240 \text{ V} = 61.83 \text{ A}$ (use 62 A)

Example No. D2(c). Optional Calculation for One-Family Dwelling with Heat Pump, Single-Phase, 240/120-V Service
(see 220.82)

The dwelling has a floor area of 2000 sq. ft. exclusive of unfinished cellar not adaptable for future use, unfinished attic, and open porches. It has a 12-kW range, 4.5-kW water heater, a 1.2-kW dishwasher, a 5-kW clothes dryer, a 2-1/2-ton (24-A) heat pump with 15-kW of backup heat.

Heat Pump kVA calculation
 $24 \text{ A} \times 240 \text{ V} \div 1000 = 5.76 \text{ kVA}$

This 5.76 kVA is less than 15 kVA of the backup heat; therefore, the heat pump load need not be included in the service calculation (see 220.82[C]).

2000 sq. ft. at 3 VA	6000 VA
Two 20-ampere appliance outlet circuits (1500 VA ea)	3000 VA
Laundry circuit	1500 VA
Range (at nameplate rating)	12,000 VA
Water heater	4500 VA
Dishwasher	1200 VA
Clothes dryer	5000 VA
Subtotal general load	33,200 VA
First 10 kVA of other load at 100% =	10,000 VA
Remainder of other load at 40% (23,200 VA X 0.4 =)	9280 VA
Total of general load	19,280 VA

Heat Pump and Supplementary Heat*
 $240 \times 24\text{A} = 5760 \text{ VA}$

15-kW electric heat:
 $5760 \text{ VA} + (15,000 \times 65\%) = 5.76 \text{ kVA} + 9.75 \text{ kVA} = 15.51 \text{ kVA}$
 $15.51 \text{ kVA at } 100\% = 15.51 \text{ kVA}$

*If supplementary heat is not at same time as heat pump, heat pump kVA need not be added to total.

Totals

Net General load	19,280 VA
Heat pump and supplementary heat	15,510 VA
Total	34,790 VA

Calculated Load for Service

$34.79 \text{ kVA} \times 1000 \div 240 \text{ V} = 144.96 \text{ A}$
Therefore, this dwelling unit would be permitted to be served by a 150-A service.

Example D8. Motor Circuit Conductors, Overload Protection, and Short-Circuit and Ground-Fault Protection

(see 240., 430.6, 430.22, 430.23, 430.24, 430.32, 430.52 and 430.62, Tables 430.52 and 430.250)

Motor Overload Protection

Where protected by a separate overload device, the motors are required to have overload protection rated or set to trip at not more than 125% of the nameplate full-load current. See 430.32(A) and 430.32(A)(1).

Where a separate overload device is an overload relay (not a fuse or circuit breaker) and the overload device selected at 125% is not sufficient to start the motor or carry the load the trip setting is permitted to be increased in accordance with 430.32(C).

Branch Circuit Short Circuit and Ground Fault Protection

The selection of the rating of protective device depends on the type of protective device selected, in accordance with 430.52 and table 430.32(C).

56

57

The following is an example for a 25 hp motor:

- (a) Non time-delay fuse: The fuse rating is $300\% \times 34\text{A} = 102\text{ A}$. The next larger standard fuse is 110 A (see 240.6 and 430.52 (C)(1), exception No. 1). If the motor will not start with a 110 A time-delay fuse, the fuse rating is permitted to increase to 125 A because this rating does not exceed 400% (see 430.52[C][1], exception No.2[A]).
- (b) Time-delay fuse: The fuse rating is $175\% \times 34\text{ A} = 59.5\text{ A}$. The next larger fuse is 60 A (see 240.6 and 430.52[C][1], exception No. 1). If the motor will not start with a 60 A time-delay fuse, the fuse rating is permitted to be increased to 70 because this rating does not exceed 225% (see 430.52[C][1], exception No. 2[b]).

Feeder Short-Circuit and Ground-Fault Protection

The rating of the feeder protective device is based on the sum of the largest branch-circuit protective device (example is 110 A) plus the sum of the full-load currents of the other motors.

Georgia's Electric Cooperatives

Altamaha EMC	Lyons	912-526-8181
Amicalola EMC	Jasper	706-253-5200
Blue Ridge Mountain EMC	Young Harris	706-379-3121
Canoochee EMC	Reidsville	912-557-4391
Carroll EMC	Carrollton	770-832-3552
Central Georgia EMC	Jackson	770-775-7857
Coastal Electric Cooperative	Midway	912-884-3311
Cobb EMC	Marietta	770-429-2100
Colquitt EMC	Moultrie	229-985-3620
Coweta-Fayette EMC	Palmetto	770-502-0226
Diverse Power	LaGrange	706-845-2000
Excelsior EMC	Metter	912-685-2115
Flint Energies	Reynolds	478-847-3415
Grady EMC	Cairo	229-377-4182
Greystone Power	Douglasville	770-942-6576
Habersham EMC	Clarksville	706-754-2114
Hart EMC	Hartwell	706-376-4714
Irwin EMC	Ocilla	229-468-7415
Jackson EMC	Jefferson	706-367-5281
Jefferson Energy	Wrens	706-547-2167
Little Ocmulgee EMC	Alamo	912-568-7171
Middle Georgia EMC	Vienna	229-268-2671
Mitchell EMC	Camilla	229-336-5221
North Georgia EMC	Dalton	706-259-9441
Ocmulgee EMC	Eastman	478-374-7001
Oconee EMC	Dudley	478-676-3191
Okefenoke EMC	Nahunta	912-462-5131
Patula EMC	Cuthbert	229-732-3171
Planters EMC	Millen	478-982-4722
Rayle EMC	Washington	706-678-2116
Satilla EMC	Alma	912-632-7222
Sawnee EMC	Cumming	770-887-2363
Slash Pines EMC	Homerville	912-487-5201
Snapping Shoals EMC	Covington	770-786-3484
Southern Rivers Energy	Barnesville	770-358-1383
Sumter EMC	Americus	229-924-8041
Three Notch EMC	Donalsonville	229-524-5377
Tri-County EMC	Gray	478-986-8100
Tri-State EMC	McCaysville	706-492-3251
Upson EMC	Thomaston	706-647-5475
Walton EMC	Monroe	770-267-2505
Washington EMC	Sandersville	478-552-2577

NOTES

